



Electronic Design[®] LIBRARY

Copyright © 2021 by Endeavor Media. All rights reserved.

A compendium of articles from *Electronic Design*

IMPEDANCE MATCHING: Essential Design Knowledge

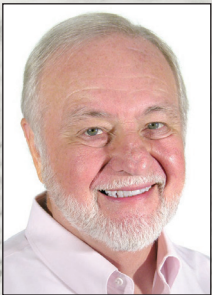

By Lou Frenzel,
Contributing Editor

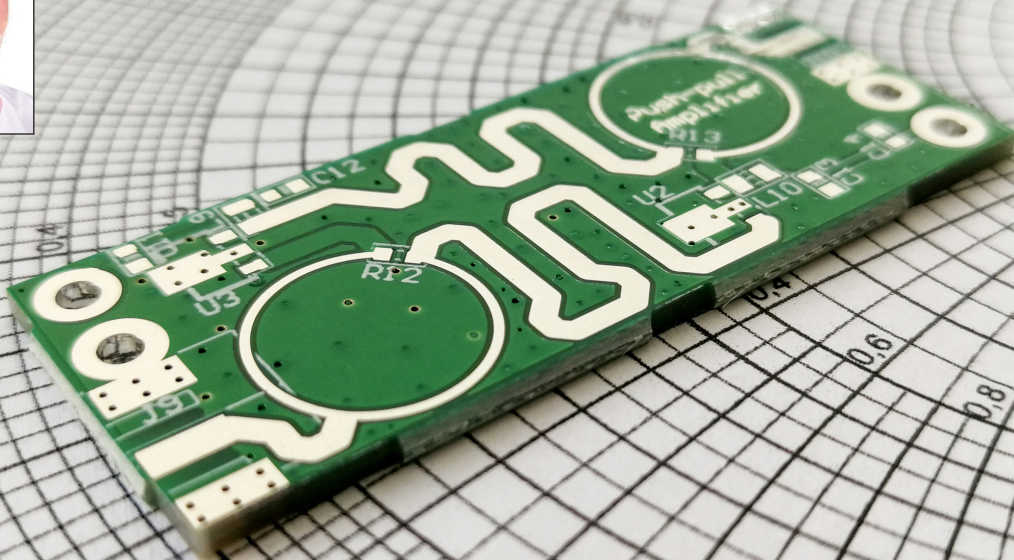

IMPEDANCE MATCHING:

Essential Design Knowledge



INTRODUCTION

02

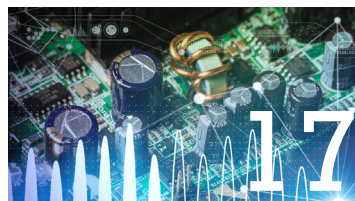

CHAPTER 3

Back to Basics:
Impedance
Matching (Part 3)

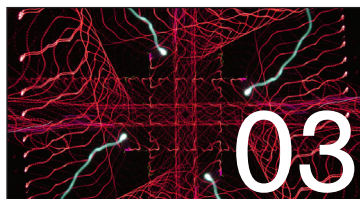

CHAPTER 1

Back to Basics:
Impedance
Matching (Part 1)



CHAPTER 4

Automatic
Impedance
Matching in RF
Design

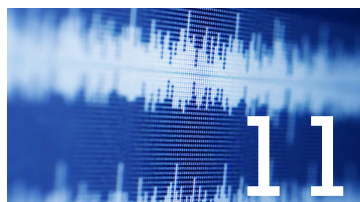

CHAPTER 2

Back to Basics:
Impedance
Matching (Part 2)

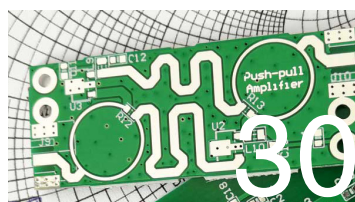

CHAPTER 5

Impedance
Matching Basics:
Smith Charts

Impedance Matching: Essential Design Knowledge

Lou Frenzel breaks down the all-important process of impedance matching, which particularly strikes at the hearts of RF engineers.



*Lou Frenzel,
Contributing Editor*

IMPEDEANCE MATCHING is one of those design processes that you use to make circuits and equipment work properly. It's a process you probably learned in college, or not. The basic rule is simple:

To achieve maximum power transfer, the load impedance should be equal to the source impedance, or some variation thereof.

Of course, there's more to it than first meets the eye. If you're an RF engineer, you probably use this process all of the time. Other engineers never seem to need it. If you're writing code for an embedded processor and interfacing it to some external circuits, you probably couldn't care less.

Here's a quickie summary of the content to help you zero in on your needs and interests:

Part 1 states the maximum power transfer theorem and goes on to illustrate its importance. Following that, some basic impedance matching circuit and methods are described. A discussion of matching audio amps to speakers concludes that not all things must be matched.

An important feature of Part 1 talks about transmission lines and how many things are interconnected with coax. It's essential to match impedances when using transmission lines, as the consequence of not matching produces high standing wave ratio (SWR) and significant power loss. Coax matching methods are provided. This part wraps up with a section on transformer impedance matching.

Part 2 focuses on impedance matching with L-networks. L-networks are the mainstay of RF impedance matching. They're simple and remarkably effective. Techniques for designing these networks are given with multiple examples.

Part 3 shows how to design pi and T-networks. These are derived from the L-network and provide a way to match a wider range of impedances with the ability of controlling Q. They're particularly useful tools in RF circuit design. This part also covers automatic matching with tunable networks. These have been widely adopted in smartphones to keep the antennas tuned for maximum output and input regardless of physical orientation and condition.

Part 4 delves into automatic Z matching. It discusses how to get your antenna to tune itself for maximum effect.

And Part 5 shows how you can use the Smith chart to do your impedance matching. Luckily, some software is available to simplify and facilitate this process.

IMPEDANCE MATCHING:

Essential Design Knowledge

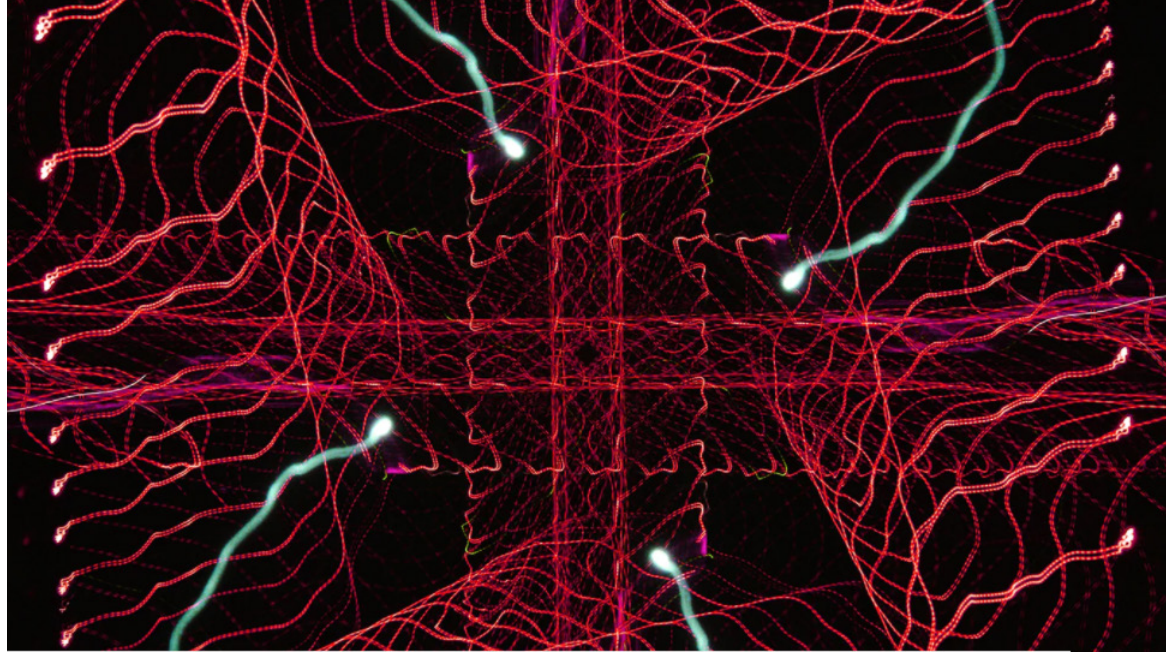

CHAPTER 1:

Back to Basics: Impedance Matching (Part 1)

LOU FRENZEL

The term “impedance matching” is rather straightforward. It’s simply defined as the process of making one impedance look like another. Frequently, it becomes necessary to match a load impedance to the source or internal impedance of a driving source.

This series summarizes the most common impedance-matching techniques.

The term “impedance matching” is rather straightforward. It’s simply defined as the process of making one impedance look like another. Frequently, it becomes necessary to match a load impedance to the source or internal impedance of a driving source.

A wide variety of components and circuits can be used for impedance matching. This series summarizes the most common impedance-matching techniques.

Rationale And Concept

The maximum power-transfer theorem says that to transfer the maximum amount of power from a source to a load, the load impedance should match the source impedance. In the basic circuit, a source may be dc or ac, and its internal resistance (R_i) or generator

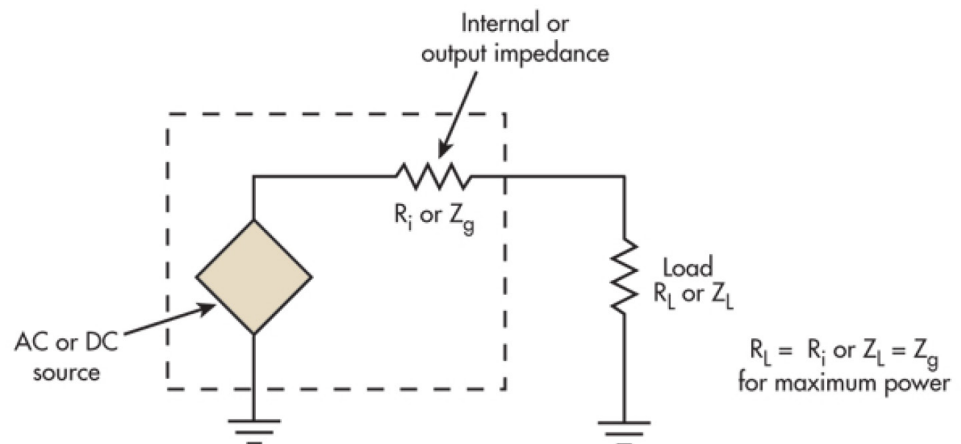

Fig 1. Maximum power is transferred from a source to a load when the load resistance equals the internal resistance of the source.

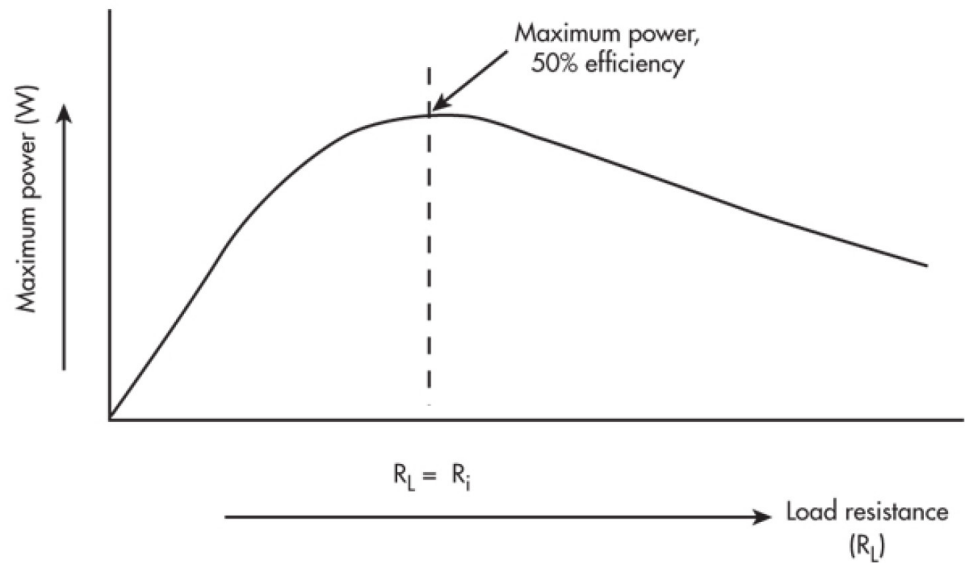

Fig 2. Varying the load resistance on a source shows that maximum power to the load is achieved by matching load and source impedances. At this time, efficiency is 50%.

output impedance (Z_g) drives a load resistance (R_L) or impedance (Z_L) (**Fig. 1**):

$$R_L = R_i \text{ or } Z_L = Z_g$$

A plot of load power versus load resistance reveals that matching load and source impedances will achieve maximum power (**Fig. 2**).

A key factor of this theorem is that when the load matches the source, the amount of power delivered to the load is the same as the power dissipated in the source. Therefore, transfer of maximum power is only 50% efficient.

The source must be able to dissipate this power. To deliver maximum power to the load, the generator has to develop twice the desired output power.

Applications

Delivery of maximum power from a source to a load occurs frequently in electronic design. One example is when the speaker in an audio system receives a signal from a power amplifier (**Fig. 3**). Maximum power is delivered when the speaker impedance matches the output impedance of the power amplifier. While this is theoretically correct, it turns out that the best arrangement is for the power amplifier impedance to be less than the speaker impedance. The reason for this is the complex nature of the speaker as a load and its

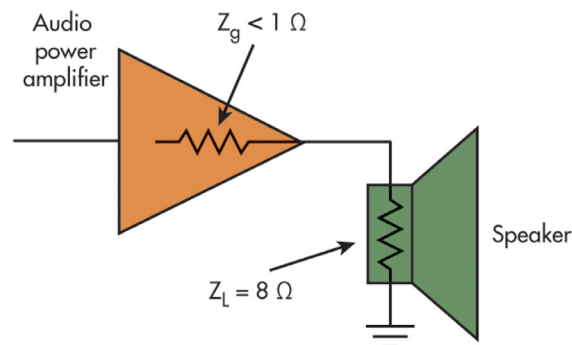

Fig 3. Unmatched impedances provide the best amplifier and speaker performance.

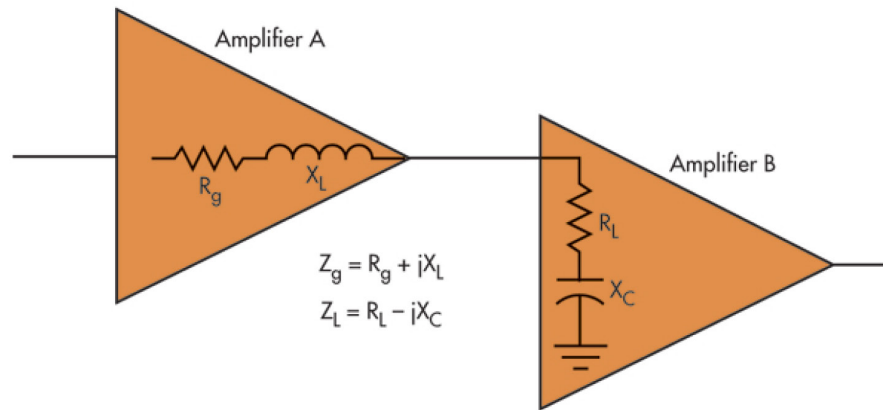
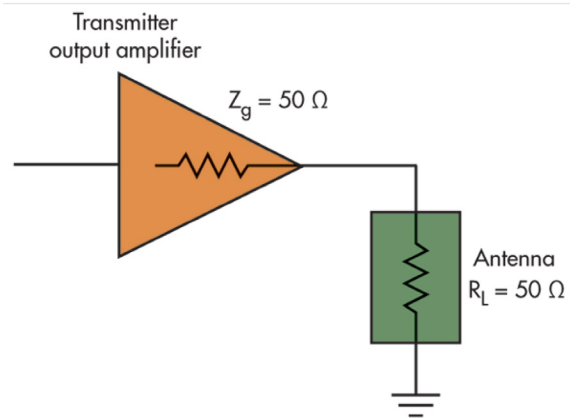

Fig 4. Impedances in radio-frequency transmitters must be matched to pass maximum power from stage to stage. Most impedances include inductances and capacitances that must also be factored into the matching process.

Fig 5. Antenna impedance must equal the transmitter output impedance to receive maximum power.



mechanical response.

Another example involves power transfer from one stage to another in a transmitter (**Fig. 4**). The complex ($R \pm jX$) input impedance of amplifier B should be matched to the complex output impedance of amplifier A. It's crucial that the reactive components cancel each other. One other example is the delivery of maximum power to an antenna (**Fig. 5**). Here, the antenna impedance matches the transmitter output impedance.

Transmission-Line Matching

This last example emphasizes another reason why impedance matching is essential. The transmitter output is usually connected to the antenna via a transmission line, which is typically coax cable. In other applications, the transmission line may be a twisted pair or some other medium.

A cable becomes a transmission line when it has a length greater than $\lambda/8$ at the operating frequency where:

$$\lambda = 300/f_{\text{MHz}}$$

For example, the wavelength of a 433-MHz frequency is:

$$\lambda = 300/f_{\text{MHz}} = 300/433 = 0.7 \text{ meters or } 27.5 \text{ inches}$$

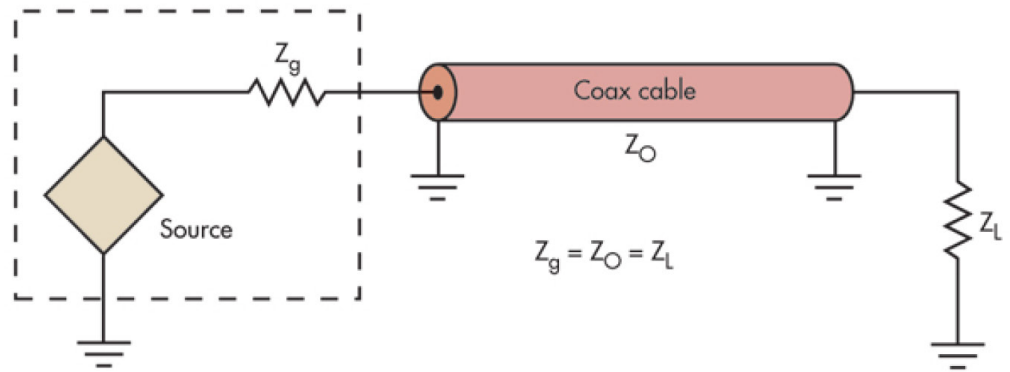

Fig 6. Transmission lines have a characteristic impedance (Z_0) that must match the load to ensure maximum power transfer and withstand loss to standing waves.

A connecting cable is a transmission line if it's longer than $0.7/8 = 0.0875$ meters or 3.44 inches. All transmission lines have a characteristic impedance (Z_0) that's a function of the line's inductance and capacitance:

$$Z_0 = \sqrt{L/C}$$

To achieve maximum power transfer over a transmission line, the line impedance must also match the source and load impedances (**Fig. 6**). If the impedances aren't matched, maximum power will not be delivered. In addition, standing waves will develop along the line. This means the load doesn't absorb all of the power sent down the line.

Consequently, some of that power is reflected back toward the source and is effectively lost. The reflected power could even damage the source. Standing waves are the distributed patterns of voltage and current along the line. Voltage and current are constant for a matched line, but vary considerably if impedances do not match.

The amount of power lost due to reflection is a function of the reflection coefficient (Γ) and the standing wave ratio (SWR). These are determined by the amount of mismatch between the source and load impedances.

The SWR is a function of the load (Z_L) and line (Z_0) impedances:

$$\text{SWR} = Z_L/Z_0 \text{ (for } Z_L > Z_0\text{)}$$

$$\text{SWR} = Z_0/Z_L \text{ (for } Z_0 > Z_L\text{)}$$

For a perfect match, $\text{SWR} = 1$. Assume $Z_L = 75 \Omega$ and $Z_0 = 50 \Omega$:

$$\text{SWR} = Z_L/Z_0 = 75/50 = 1.5$$

The reflection coefficient is another measure of the proper match:

$$\Gamma = (Z_L - Z_0)/(Z_L + Z_0)$$

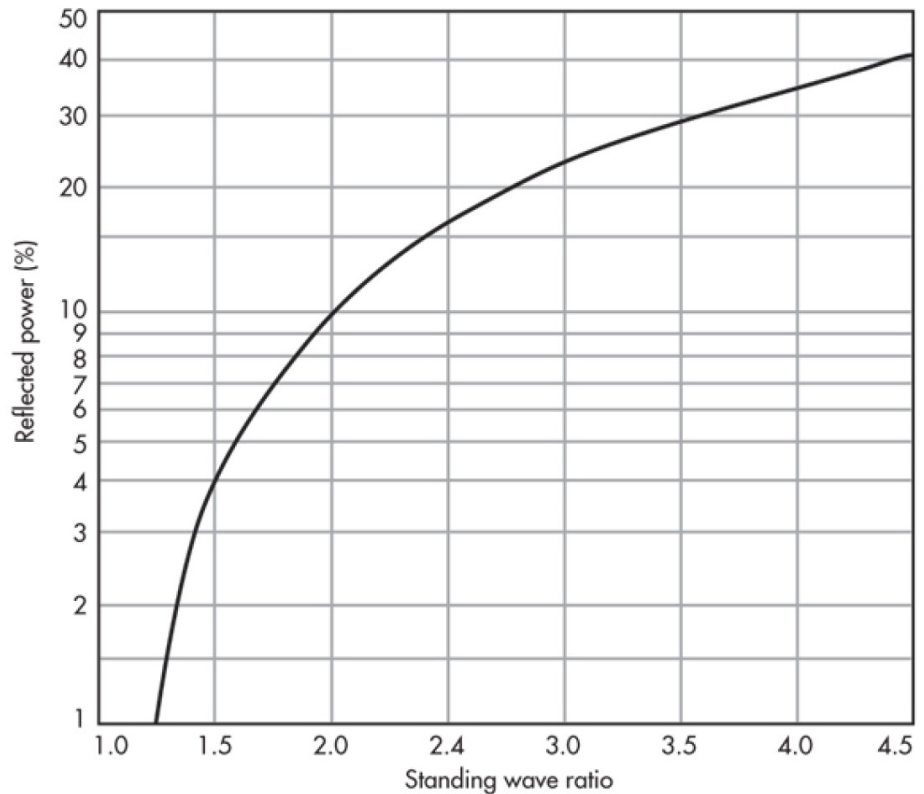

Fig 7. This plot illustrates reflected power in an unmatched transmission line with respect to SWR.

For a perfect match, Γ will be 0. You can also compute Γ from the SWR value:

$$\Gamma = (\text{SWR} - 1)/(\text{SWR} + 1)$$

Calculating the above example:

$$\Gamma = (\text{SWR} - 1)/(\text{SWR} + 1) = (1.5 - 1)/(1.5 + 1) = 0.5/2.5 = 0.2$$

Looking at amount of power reflected for given values of SWR (**Fig. 7**), it should be noted that an SWR of 2 or less is adequate for many applications. An SWR of 2 means that reflected power is 10%. Therefore, 90% of the power will reach the load.

Keep in mind that all transmission lines like coax cable do introduce a loss of decibels per foot. That loss must be factored into any calculation of power reaching the load. Coax datasheets provide those values for various frequencies.

Another important point to remember is that if the line impedance and load are matched, line length doesn't matter. However, if the line impedance and load don't match, the generator will see a complex impedance that's a function of the line length.

Reflected power is commonly expressed as return loss (R_L). It's calculated with the expression:

$$R_L \text{ (in dB)} = 10\log(P_{IN}/P_{REF})$$

PIN represents the input power to the line and PREF is the reflected power. The greater the dB value, the smaller the reflected power and the greater the amount of power delivered to the load.

Impedance Matching

The common problem of mismatched load and source impedances can be corrected by connecting an impedance-matching device between source and load (**Fig. 8**). The impedance (Z) matching device may be a component, circuit, or piece of equipment.

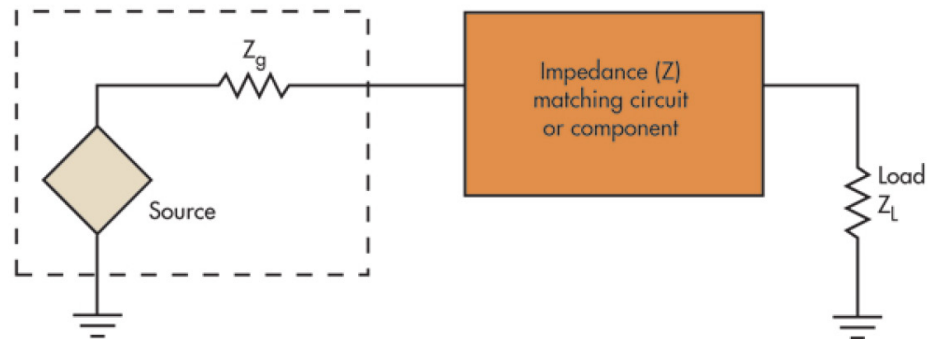

Fig 8. An impedance-matching circuit or component makes the load match the generator impedance.

A wide range of solutions is possible in this scenario. Two of the simplest involve the transformer and the $\lambda/4$ matching section. A transformer makes one impedance look like another by using the turns ratio (**Fig. 9**):

$$N = N_s/N_p = \text{turns ratio}$$

N is the turns ratio, N_s is the number of turns on the transformer's secondary winding, and N_p is the number of turns on the transformer's primary winding. N is often written as the turns ratio $N_s:N_p$.

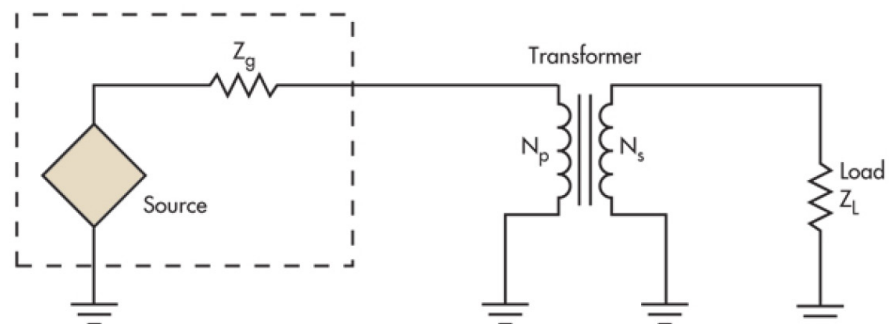

Fig 9. A transformer offers a near ideal method for making one impedance look like another.

The relationship to the impedances can be calculated as:

$$Z_s/Z_p = (N_s/N_p)^2$$

or:

$$N_s/N_p = \sqrt{(Z_s/Z_p)}$$

Z_p represents the primary impedance, which is the output impedance of the driving source (Z_g). Z_s represents the secondary, or load, impedance (Z_L).

For example, a driving source's 300- Ω output impedance is transformed into 75 Ω by a transformer to match the 75- Ω load with a turns ratio of 2:1:

$$N_s/N_p = \sqrt{(Z_s/Z_p)} = \sqrt{(300/75)} = \sqrt{4} = 2$$

The highly efficient transformer essentially features a wide bandwidth. With modern ferrite cores, this method is useful up to about several hundred megahertz.

An autotransformer with only a single winding and a tap can also be used for impedance matching. Depending on the connections, impedances can be either stepped down (**Fig. 10a**) or up (**Fig. 10b**).

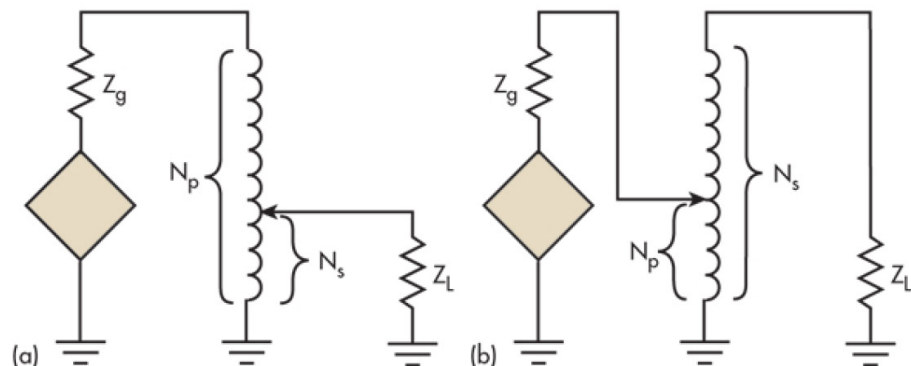

Fig 10. A single-winding autotransformer with a tap can step down (a) or step up (b) impedances like a standard two-winding transformer.

The same formulas used for standard transformers apply. The transformer winding is in an inductor and may even be part of a resonant circuit with a capacitor.

A transmission-line impedance-matching solution uses a $\lambda/4$ section of transmission line (called a Q-section) of a specific impedance to match a load to source (Fig. 11):

$$Z_Q = \sqrt{(Z_O Z_L)}$$

where Z_Q = the characteristic impedance of the Q-section line; Z_O = the characteristic impedance of the input transmission line from the driving source; and Z_L = the load impedance.

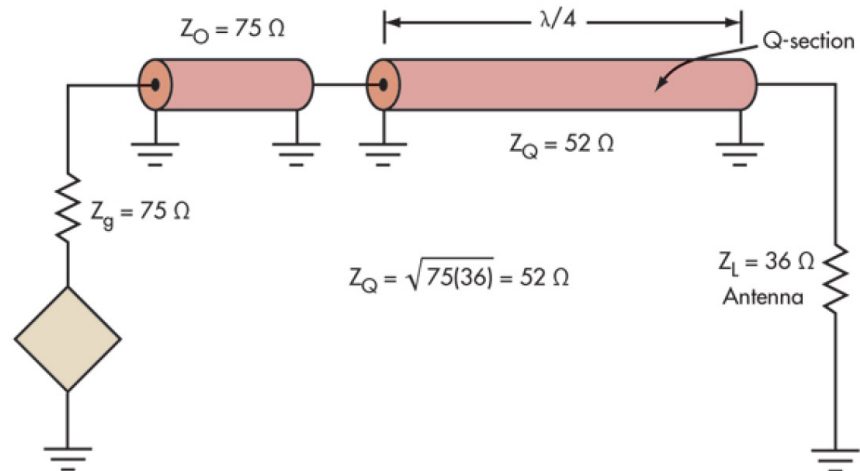

Fig 11. A $\lambda/4$ Q-section of transmission line can match a load to a generator at one frequency.

Here, the 36- Ω impedance of a $\lambda/4$ vertical ground-plane antenna is matched to a 75- Ω transmitter output impedance with a 52- Ω coax cable. It's calculated as:

$$Z_Q = \sqrt{(75)(36)} = \sqrt{2700} = 52 \Omega$$

Assuming an operating frequency of 50 MHz, one wavelength is:

$$\lambda = 300/\text{fMHz} = 300/50 = 6 \text{ meters or about 20 feet}$$

$$\lambda/4 = 20/4 = 5 \text{ feet}$$

Assuming the use of 52- Ω RG-8/U coax transmission line with a velocity factor of 0.66:

$$\lambda/4 = 5 \text{ feet } (0.66) = 3.3 \text{ feet}$$

Several important limitations should be considered when using this approach. First, a cable must be available with the desired characteristic impedance. This isn't always the case, though, because most cable comes in just a few basic impedances (50, 75, 93, 125 Ω). Second, the cable length must factor in the operating frequency to compute wavelength and velocity factor.

In particular, these limitations affect this technique when used at lower frequencies. However, the technique can be more easily applied at UHF and microwave frequencies when using microstrip or stripline on a printed-circuit board (PCB). In this case, almost any desired characteristic impedance may be employed.

The next part of this series will explore more popular impedance-matching techniques.

to view this article online, [click here](#)

[BACK TO TABLE OF CONTENTS](#)

IMPEDANCE MATCHING:

Essential Design Knowledge

The L-network is a simple inductor-capacitor (LC) circuit that can be used to match a wide range of impedances in RF circuits. Any RF circuit application covering a narrow frequency range is a candidate for an L-network.

CHAPTER 2:

Back to Basics: Impedance Matching (Part 2)

LOU FRENZEL

During impedance matching, a specific electronic load (R_L) is made to match a generator output impedance (R_g) for maximum power transfer. The need arises in virtually all electronic circuits, especially in RF circuit design.

“Back to Basics: Impedance Matching (Part 1)” discusses the use of a transformer as a basic way to match impedance. This article will introduce the L-network, which is a simple inductor-capacitor (LC) circuit that can be used to match a wide range of impedances in RF circuits.

L-Network Applications And Configurations

The primary applications of L-networks involve impedance matching in RF circuits, transmitters, and receivers. L-networks are useful in matching one amplifier output to the input of a following stage. Another use is matching an antenna impedance to a transmitter output or a receiver input. Any RF circuit application covering a narrow frequency range is a candidate for an L-network.

There are four basic versions of the L-network, with two low-pass versions and two high-pass versions (**Fig. 1**). The low-pass versions are probably the most widely used since they attenuate harmonics, noise, and other undesired signals, as is usually necessary in RF designs. The key design criteria are the magnitudes and relative sizes of the driving generator output impedance and load impedance.

The impedances that are being matched determine the Q of the circuit, which cannot be specified or controlled. If it is essential to control Q and bandwidth, a T or p-network is a better choice. These choices will be covered in a subsequent article.

While the L-network is very versatile, it may not fit every need. There are limits to the range of impedances that it can match. In some instances, the calculated values of inductance or capacitance may be too large or small to be practical for a given frequency range.

This problem can sometimes be overcome by switching from a low-pass version to a high-pass version or vice versa.

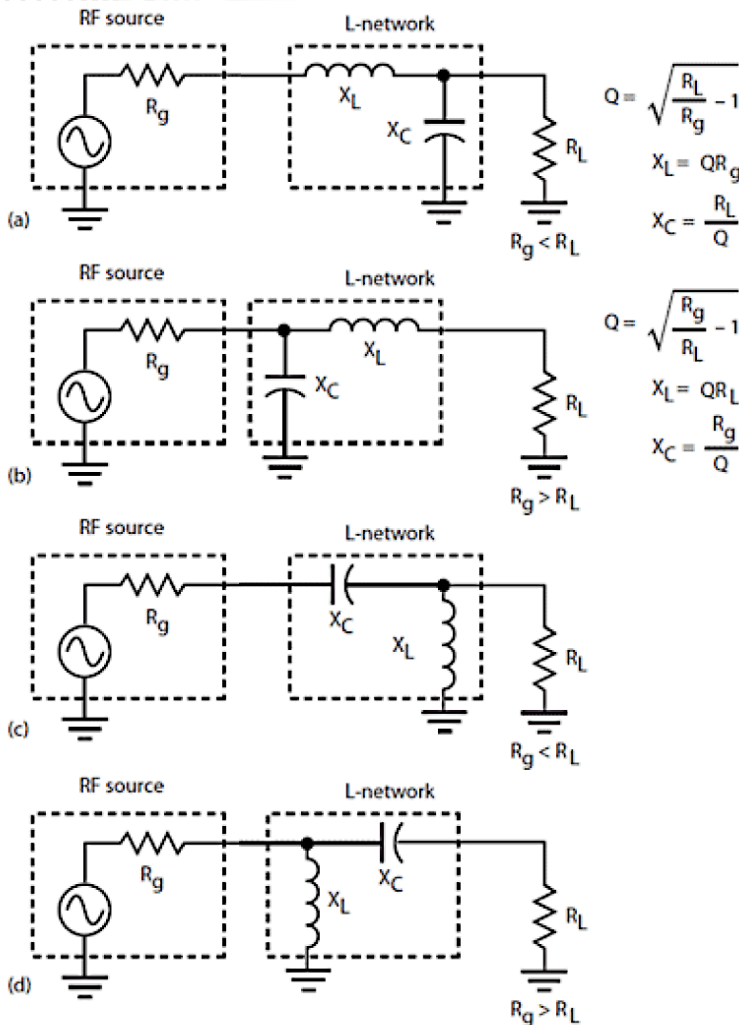

Design Example #1

The goal is to match the output impedance of a low-power RF transistor amplifier to a 50-ohm output load, and 50 Ω is a universal standard for most receiver, transmitter, and RF circuits. Most power amplifiers have a low output impedance, typically less than 50 Ω .

Figure 2 shows the desired circuit. Assume an amplifier output (generator) impedance of 10 Ω at a frequency of 76 MHz. Calculate the needed inductor and capacitor values using the formulas given in Figure 1a:

$$Q = \sqrt{(R_L/R_g) - 1}$$

$$Q = \sqrt{(50/10) - 1} = \sqrt{(5) - 1} = \sqrt{4} = 2$$

$$X_L = QR_g = 2(10) = 20 \Omega$$

$$L = X_L/2\pi f$$

$$L = 20 / [2(3.14)(76 \times 10^6)]$$

$$L = 42 \text{ nH}$$

$$X_C = R_L/Q$$

$$X_C = 50/2 = 25 \Omega$$

$$C = 1/2\pi f X_C$$

$$C = 1 / [2(3.14)(76 \times 10^6)(25)]$$

$$C = 83.8 \text{ pF}$$

This solution omits any output impedance reactance such as transistor amplifier output capacitance or inductance and any load reactance that could be shunt capacitance or series inductance. When these factors are known, the computed values can be compensated.

The bandwidth (BW) of the circuit is relatively wide given the low Q of 2:

1. There are four basic L-network configurations. The network to be used depends on the relationship of the generator and load impedance values. Those in (a) and (b) are low-pass circuits, and those in (c) and (d) are high-pass versions.

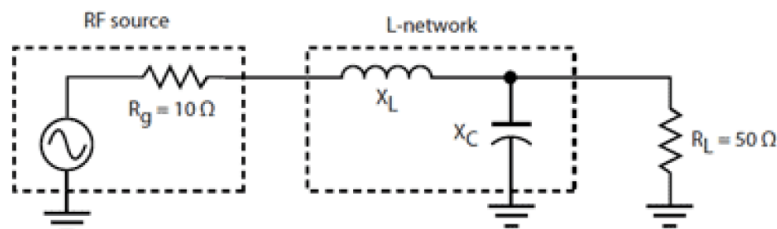

2. The RF source is a transistor amplifier with an output impedance of 10 Ω that is to be matched to 50-Ω output impedance load. The L-network with a parallel output capacitor is used.

$$BW = f/Q = 76 \times 10^6 / 2 = 38 \times 10^6 = 38 \text{ MHz}$$

You can see how this matching network functions by converting the parallel combination of the 50-Ω resistive load and the 25-Ω capacitive reactance into its series equivalent (**Fig. 3**):

$$R_s = R_p / (Q^2 + 1)$$

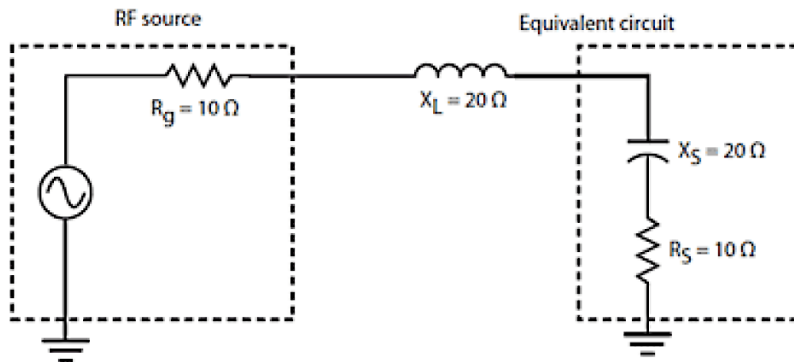

$$R_s = 50 / (2^2 + 1) = 10 \text{ Ω}$$

$$X_s = X_p \sqrt{[(Q^2 + 1) / Q^2]}$$

$$X_s = 25 / (5/4) = 25 / 1.25 = 20 \text{ Ω}$$

Note how the series equivalent capacitive reactance equals and cancels the series inductive reactance. Also the series equivalent load of 10 Ω matches the generator resistance for maximum power transfer.

3. The equivalent circuit of the network in Figure 2 is a simple series RLC network where the reactances cancel and the source and load impedances match.

Parallel and Series Circuit Equivalents

Sometimes it's necessary to convert a series RC or RL circuit into an equivalent parallel RC or RL circuit or vice versa. Such conversions are useful in RLC circuit analysis and design (**Fig. 4**).

These equivalents also can help explain how the L-networks and other impedance-matching circuits work. The designations are:

R_s = series resistance

R_p = parallel resistance

X_s = series reactance

X_p = parallel reactance

The conversion formulas are:

$$R_s = R_p / (Q^2 + 1)$$

$$X_s = X_p \sqrt{[(Q^2 + 1) / Q^2]}$$

$$R_p = R_s (Q^2 + 1)$$

$$X_p = X_s \sqrt{[(Q^2 + 1) / Q^2]}$$

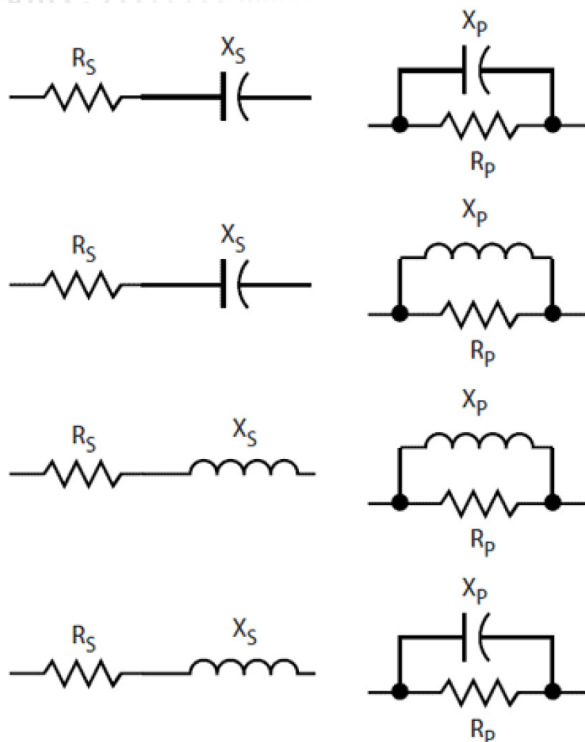

4. These are all of the possible practical series and parallel RC and RL circuit equivalents. The text provides the calculations for them.

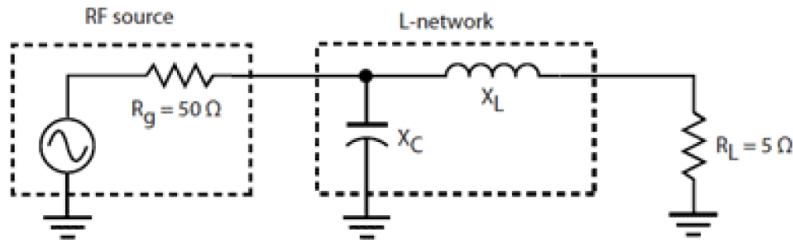

5. The RF source is a transmitter at 433 MHz with an output impedance of 50 Ω. The load is a loop antenna with an impedance of 5 Ω.

$$Q = \sqrt{[R_p / (R_s - 1)]}$$

$$Q = X_L / R_s$$

$$Q = R_p / X_C$$

If the Q is greater than 5, you can use the simplified approximations:

$$R_p = Q^2 R_s$$

$$X_p = X_s$$

Design Example #2

Match the output impedance of 50 Ω from a 433-MHz industrial-scientific-medical (ISM) band transmitter to a 5-Ω loop antenna impedance (**Fig. 5**).

$$Q = \sqrt{[(R_g / R_L) - 1]}$$

$$Q = \sqrt{[(50/5) - 1]} = \sqrt{[(10) - 1]} = \sqrt{9} = 3$$

$$X_L = QR_L = 3(5) = 15 \Omega$$

$$L = X_L / 2\pi f$$

$$L = 15 / [2(3.14)(433 \times 10^6)]$$

$$L = 5.52 \text{ nH}$$

$$X_C = R_g / Q$$

$$X_C = 50 / 3 = 16.67 \Omega$$

$$C = 1 / 2\pi f X_C$$

$$C = 1 / [2(3.14)(433 \times 10^6)(16.67)]$$

$$C = 22 \text{ pF}$$

In this example, the capacitor, inductor, and load resistance form a parallel resonant circuit (**Fig. 6**).

Recall that a parallel resonant circuit acts like an equivalent resistance. That resonant equivalent resistance (R_R) of a parallel RLC circuit can be calculated by:

$$R_R = L / CR$$

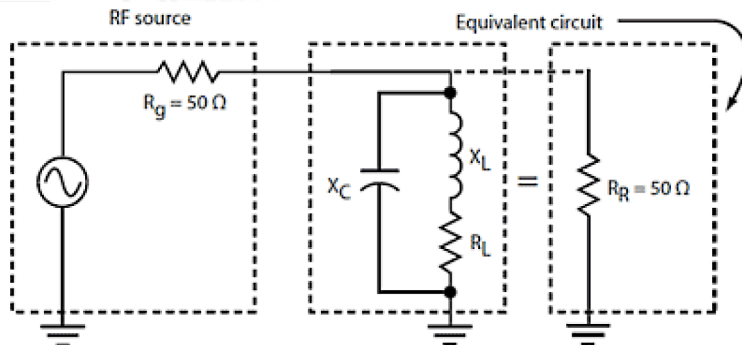

6. The equivalent circuit of the L-network and load is a parallel resonant circuit. At resonance, the parallel circuit has an equivalent resistance equal to the generator resistance of 50 Ω for a match.

or:

$$R_R = R(Q^2 + 1)$$

$$R_R = L/CR = 5.52 \times 10^{-9}/(22 \times 10^{-12})(5) = 50.18 \Omega$$

$$R_R = R(Q^2 + 1) = 5(3^2 + 1) = 50 \Omega$$

In both cases the parallel resonant load equivalent resistance is 50Ω and equal to the generator resistance allowing maximum power transfer. Again, adjustments in these values should be made to include any load reactive component. The equivalent high-pass networks could also be used. One benefit is that the series capacitor can block dc if required.

A Modern Application

In radio communications, a common problem is matching a transmitter, receiver, or transceiver to a given antenna. Most transceivers are designed with a standard $50\text{-}\Omega$ input or output impedance. Antenna impedances can vary widely from a few ohms to over a thousand ohms.

To meet the need to match a transceiver to an antenna, the modern antenna tuner has been developed. Manual versions with tunable capacitors and switched tapped inductors have been available for years. Today, modern antenna tuners are automated. When the transceiver is in the transmit mode, the tuner automatically adjusts to ensure the best impedance match possible for maximum power transfer.

Figure 7 shows a representative tuner. It is essentially an L-network that is adjusted automatically by switching different values of capacitance in or out and/or switching different taps on the inductor to vary the inductance. A microcontroller performs the switching according to some algorithm for impedance matching.

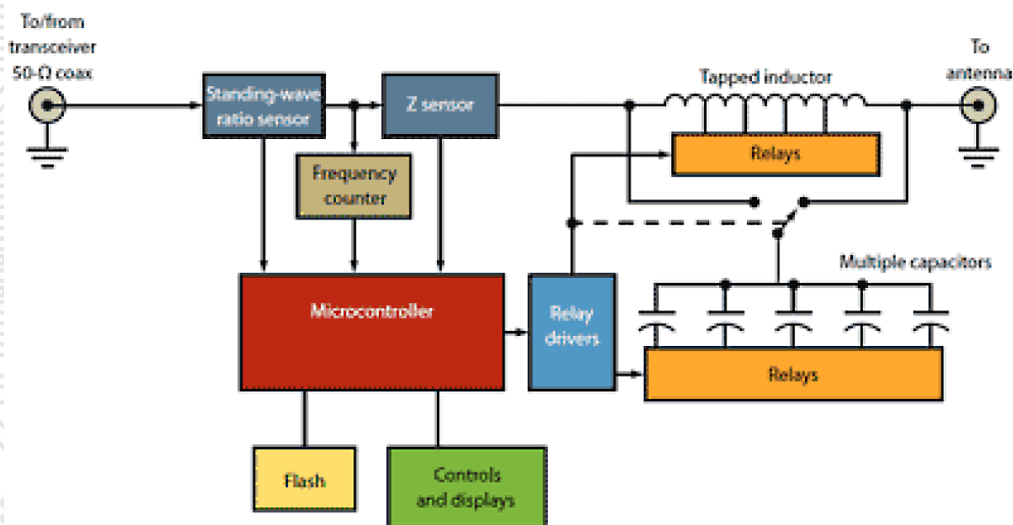

7. The basic impedance-matching circuit in the MFJ Enterprises MFJ928 automatic antenna tuner is an L-network with a switched tapped inductor and switched capacitors. SWR, impedance, and frequency sensors provide inputs to the microcontroller whose algorithm switches the network seeking an impedance match.

The criterion for determining a correct match is measuring the standing wave ratio (SWR) on the transmission line. The SWR is a measure of the forward and reflected power on a transmission line. If impedances are properly matched, there will be no reflected power and all generated power will be sent to the antenna. The most desirable SWR is 1:1 or 1. Anything higher indicates reflected power and a mismatch. For example, an SWR value of 2 indicates a reflected power of approximately 11%.

In Figure 7, a special SWR



sensor circuit measures forward and reflected power and provides proportional dc values to the microcontroller. The microcontroller has internal analog-to-digital converters (ADCs) to provide binary values to the impedance-matching algorithm. Other inputs to the microcontroller are the frequency from a frequency counter circuit and the actual complex load impedance as measured by an impedance-measuring circuit.

One typical commercial automated antenna tuner, the MFJ Enterprises MFJ-928, has an operating frequency range of 1.8 to 30 MHz and can handle RF power up to 200 W. It has an SWR matching range of 8:1 for impedances less than 50 Ω and up to 32:1 for impedances greater than 50 Ω .

The total impedance-matching range is for loads in the 6- to 1600- Ω range. The range of capacitance is 0 to 3900 pF in 256 steps, and the range inductance is 0 to 24 μ H in 256 steps. Note that the capacitance may be switched in before or after the inductor. This provides a total of 131,072 different L/C matching combinations.

Such automatic tuners are widely used in amateur radio and the military where multiple antennas on different frequencies may be used. The approach is also used in high-power industrial applications, such as matching the complex impedance of a semiconductor etch chamber in an RF plasma etcher to the 50- Ω kilowatt power amplifier output. Motors are often used to vary the capacitors and inductors in a closed loop servo feedback system.

to view this article online,  [click here](#)

 **BACK TO TABLE OF CONTENTS**

IMPEDANCE MATCHING:

Essential Design Knowledge

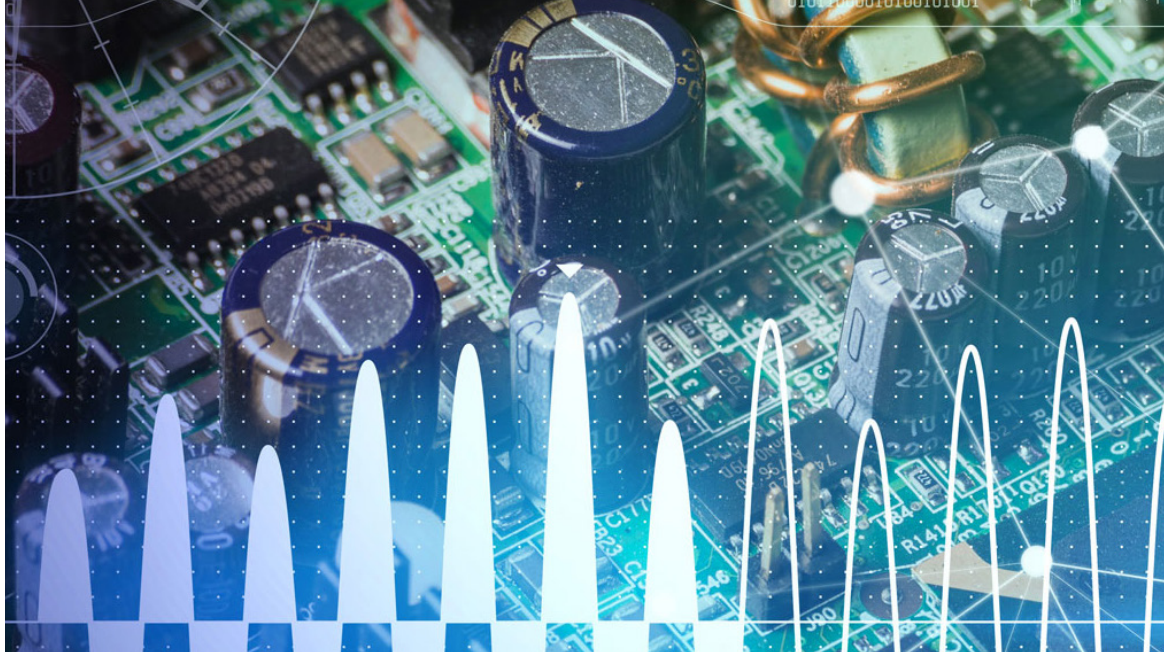

CHAPTER 3:

Back to Basics: Impedance Matching (Part 3)

LOU FRENZEL

An article about how to design basic impedance matching networks using the pi and T-networks for improved selectivity.

The L-network is a real workhorse impedance-matching circuit (see “*Back to Basics: Impedance Matching (Part 2)*”). While it fits many applications, a more complex circuit will provide better performance or better meet desired specifications in some instances. The T-networks and p-networks described here will often provide the needed improvement while still matching the load to the source.

Rationale For Use

The main reason to employ a T-network or p-network is to get control of the circuit Q. In designing an L-network, the Q is a function of the input and output impedances. You end up with a fixed Q that may or may not meet your design specs. In most cases the Q is very low (<10). This may be too low for applications where you need to limit the bandwidth to reduce harmonics or help filter out adjacent signals without the use of additional filters. Remember the relationship for determining Q:

$$Q = f/BW$$

where f is the operating frequency and BW is the bandwidth.

The T-networks and p-networks provide enough variety to fit almost any situation.

p-Networks

The basic p-network’s primary application is to match a high impedance source to lower value to load impedance. It can also be used in reverse to match a low impedance to a higher impedance. The low pass version in **Figure 1a** is the most common configuration, though the high pass version in **Figure 1b** also can be used.

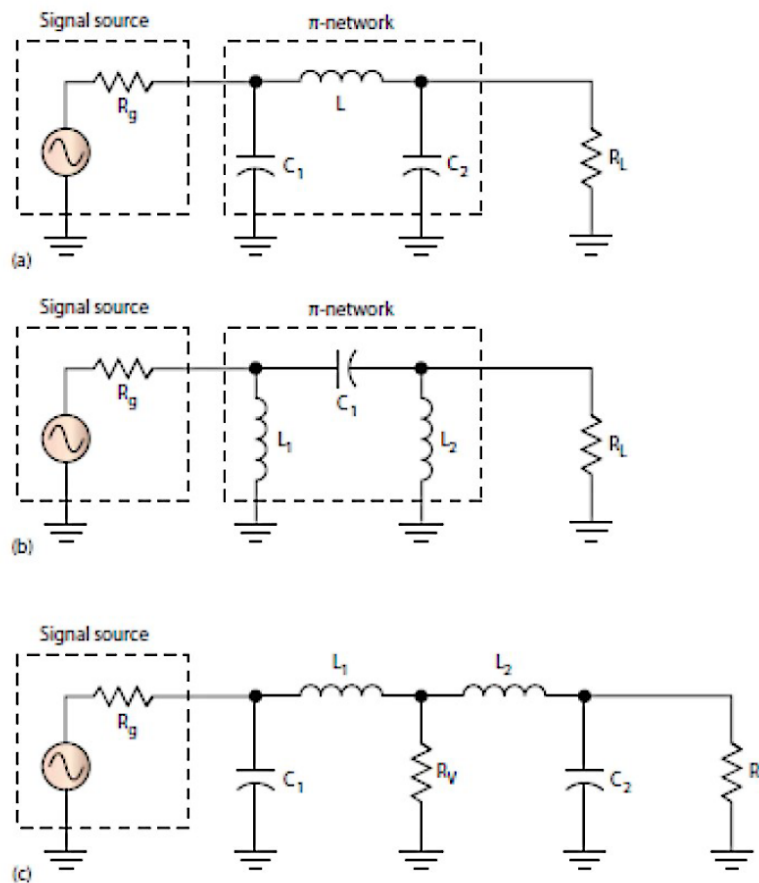

1. The π -network matching circuit is used mostly in high- to low-impedance transformations. The basic circuit (a) is a low pass circuit. A high pass version (b) can also be used. The π -network also can be considered two back-to-back L-networks with a virtual impedance between them (c).

You may design a p-network using L-network procedures. The p-network can be considered as two L-networks back to back. To use the L-network procedures, you need to assume an intermediate virtual load/source resistance R_V as shown in **Figure 1c**. You can estimate R_V from:

$$R_V = R_H / (Q^2 + 1)$$

R_H is the higher of the two design impedances R_g and R_L . The resulting R_V will be lower than either R_g or R_L depending on the desired Q . Typical Q values are usually in the 5 to 20 range. An example will illustrate the process.

p-Network Design Example

Assume you want to match a 1000- Ω source to a 100- Ω load at frequency (f) of 50 MHz. You desire a bandwidth (BW) of 6 MHz. The Q must be:

$$Q = f/BW = 50/6 = 8.33$$

$$R_V = R_H / (Q^2 + 1) = 1000 / [(8.33)^2 + 1] = 1000/70.4 = 14.2 \Omega$$

The design procedure for the first L-section uses the formulas from “*Back to Basics: Impedance Matching (Part 2)*.”

Use the desired Q of 8.33 with an R_L value equal to R_V .

The inductor L_1 value is:

$$X_L = QR_L = 8.333(14.2) = 118.3 \Omega$$

$$L = X_L / 2\pi f$$

$$L_1 = 118.3 / (2 \cdot 3.14) (50 \times 10^6)$$

$$L_1 = 376.7 \text{ nH}$$

The capacitor C_1 value is:

$$X_{C1} = R_g / Q$$



$$X_{C1} = 1000/8.33 = 120 \Omega$$

$$C_1 = 1/2\pi f X_C$$

$$C_1 = 1/[2(3.14)(50 \times 10^6)(120)]$$

$$C_1 = 26.54 \text{ pF}$$

Now calculate the second section with L_2 and C_2 using an R_g value of R_v or 14.2Ω with the load R_L of 100Ω . The Q is now defined by the L-network relationship:

$$Q = \sqrt{(R_L/R_g)} - 1$$

R_g in this case is R_v or 14.2Ω .

$$Q = \sqrt{(100/14.2)} - 1 = \sqrt{7} - 1 = \sqrt{6} = 2.46$$

The inductance L_2 , then, is:

$$X_{L2} = QR_g = 2.46(14.2) = 35 \Omega$$

$$L_2 = X_L/2\pi f$$

$$L_2 = 35/[2(3.14)(50 \times 10^6)]$$

$$L_2 = 111.25 \text{ nH}$$

The capacitance C_2 is:

$$X_{C2} = R_L/Q$$

$$X_C = 100/2.46 = 40.65 \Omega$$

$$C_2 = 1/2\pi f X_C$$

$$C_2 = 1/[2(3.14)(50 \times 10^6)(40.65)]$$

$$C_2 = 78.34 \text{ pF}$$

Note that the two inductances are in series so the total is just the sum of the two or:

$$L_1 + L_2 = 376.7 + 111.25 = 487.97 \text{ nH}$$

Figure 2 shows the final circuit.

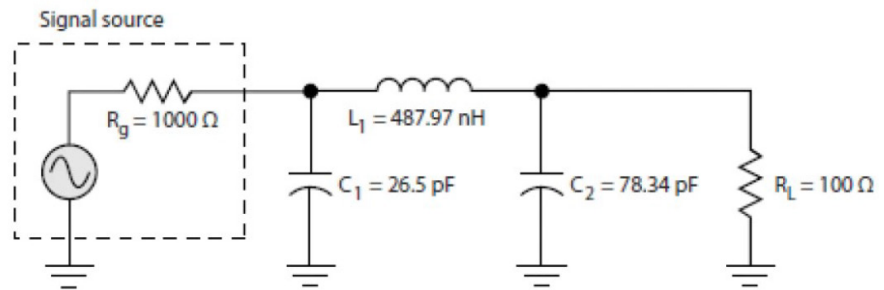

2. The π -network resulting from the example problem matches a 1000- Ω generator to a 100- Ω load at a frequency of 50 MHz with a bandwidth of 6 MHz and a Q of 8.33.

This Web tool provides the same results:

<http://bwrc.eecs.berkeley.edu/research/rf/projects/60ghz/matching/impmatch.html%20>

T-Networks And LCC Design Example

Figure 3 illustrates the basic T-networks. The basic T shown in **Figure 3a** is not widely used, but its variation in **Figure 3b** is. The second network is called an LCC network.

To design these networks, you can also consider them as two cascaded L-networks. However, since the version in **Figure 3b** is so common, you can also use some shortcut formulas. Here is the procedure:

1. Select the desired bandwidth and calculate Q.

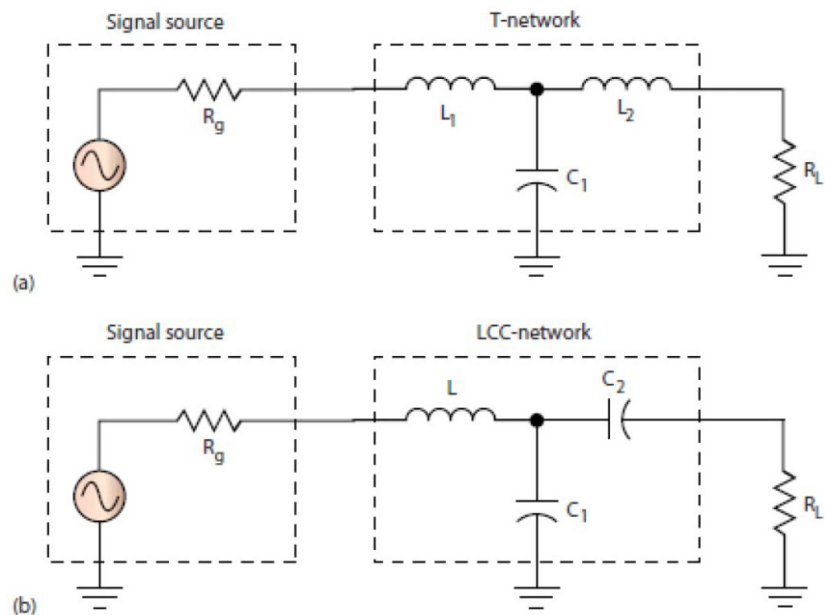

3. There are two versions of the T-network, an alternate matching network: the low pass version (a) and the more popular LCC network (b).

2. Calculate $X_L = QR_g$
3. Calculate $XC_2 = R_L \sqrt{[R_g (Q^2 + 1)/R_L - 1]}$
4. Calculate $XC_1 = R_g (Q^2 + 1)/Q[QR_L/(QR_L - XC_2^2)]$
5. Calculate the inductance $L = X_L/2\pi f$
6. Calculate the capacitances $C = 1/2\pi f X_C$

Assume a source or generator resistance of 10Ω and a load resistance of 50Ω . Let Q be 10 and the operating frequency be 315 MHz.

$$X_L = QR_g = 10(10) = 100 \Omega$$

$$L = X_L/2\pi f = 100/2(3.14)(315 \times 10^6) = 50 \text{ nH}$$

$$XC_2 = R_L \sqrt{[R_g (Q^2 + 1)/R_L - 1]} = 50 \sqrt{[(10(101)/50) - 1]} = 219 \Omega$$

$$XC_1 = R_g (Q^2 + 1)/Q [QR_L/(QR_L - XC_2^2)] = 10(101)/10[500/(500 - 219^2)] = 179 \Omega$$

$$C_2 = 1/2\pi f X_C = 1/2(3.14)(315 \times 10^6)(219) = 2.31 \text{ pF}$$

$$C_1 = 1/2\pi f X_C = 1/2(3.14)(315 \times 10^6)(179) = 2.82 \text{ pF}$$

Applications With Tunable Networks

Impedance-matching networks must be tunable before they can be used over a wider frequency range or match a wider range of impedances for lower standing wave ratio (SWR) values. One or more of the components must be variable to make such networks. While manually variable capacitors and inductors are available, they are too large

for practical modern circuits and their variability cannot be controlled electronically. Electronic control permits automatic tuning and matching circuits to be built.

Different types of electronically variable capacitors are now available to implement such automatic tuners and matching circuits. The varactor diode or voltage variable capacitor has been available for years, and its continuously variable nature over a wide capacitance range is desirable. However, it is nonlinear and requires

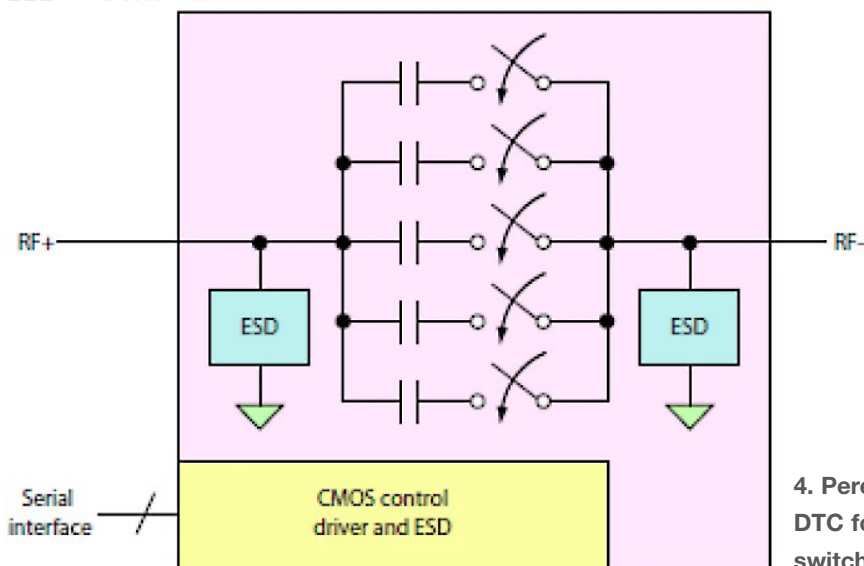

4. Peregrine Semiconductor's solid-state UltraCMOS DTC for wireless applications uses five MOSFET switched capacitors.



a significantly high bias voltage for control. Two other available options are the digitally tunable capacitor and the microelectromechanical-systems (MEMS) switched capacitor. Both are available in IC form and are ideal for making high-frequency variable matching networks.

Peregrine Semiconductor's PE64904 and PE64905 Digitally Tunable Capacitors (DTCs) consist of five fixed capacitors switched by an array of MOSFET switches (**Fig. 4**). These devices are made using a unique silicon-on-sapphire process. The capacitance is changed by a serial 5-bit code word using either a serial peripheral interface (SPI) or an I²C interface. The capacitor may be used in a series or parallel format. Maximum shunt capacitance is 5.1 pF with a minimum of 1.1 pF. Maximum series capacitance is 4.6 pF with a minimum of 0.6 pF. The capacitors can be put in series or parallel for larger or smaller values.

Figure 5 shows a circuit using several of these capacitors. It's both a tunable filter and impedance-matching circuit. It's also a reconfigurable coupled resonator topology that's widely used in band-pass filters and impedance-matching networks. Using external inductors, this network provides wide impedance coverage over the cellular phone bands of 698 to 960 MHz and 1710 to 2170 MHz. Such tunable networks can provide automatic adjustment when cell sites are changed or can correct for the antenna detuning when the phone is held.

Wispy's MEMS devices also are commercially available tunable capacitors. The basic element is a MEMS capacitor that can be switched to produce an incremental change of 0.125 pF per bit. Each capacitor comprises a fixed plate with a dielectric on its surface. Above it is a mechanical flap forming the other plate. When an electrostatic charge is applied to the plates, they're attracted to one another. The upper plate is pulled downward, significantly decreasing plate spacing and increasing capacitance. By forming an array of these tiny capacitors, larger values can be created.

The company makes several versions of this device including custom circuits. Capacitance values to a maximum of 10, 20, or 30 pF can be formed with a tuning range of 10:1. The capacitance is controlled digitally with a serial word using either an SPI or the MIPI radio-frequency front-end (RFFE) interface. Capacitive devices use external inductors.

Also, WiSpry's WS2017 standard impedance matching network is a variable p-network matching device featuring on-chip inductors. Again, the primary application is automatic tuning and impedance matching in cell phones and other small RF equipment. It operates over the 824- to 2170-MHz frequency range. An on-chip dc-dc converter provides the high voltage to operate the switchable capacitors. The device uses an SPI for control. A similar product, the WS2018, has similar specifications as well as the MIPI RFFE interface.

to view this article online,  [click here](#)

 [BACK TO TABLE OF CONTENTS](#)

IMPEDANCE MATCHING:

Essential Design Knowledge

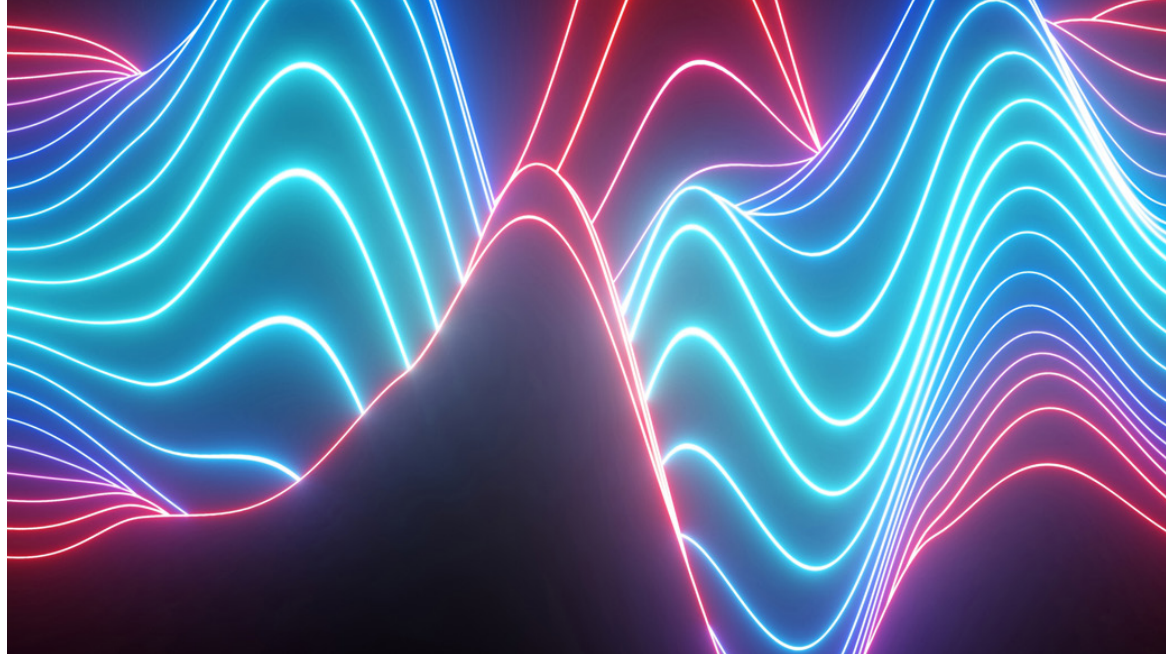

CHAPTER 4:

Automatic Impedance Matching in RF Design

LOU FRENZEL

This article takes a look at the Z-matching techniques used to get an antenna to tune itself for maximum effect.

Impedance (Z) matching is an essential part of most RF circuit design. Regardless of what you're designing, getting as much power to a load is a top target. Impedances must be matched to transfer the maximum amount of signal power between stages. And in power amplifiers (PAs), impedance matching is critical to getting the maximum power to the final load and maintaining PA linearity. Impedance matching to an antenna in a receiver or transmitter is an essential process.

Some loads are constant; thus, a single fixed Z-matching circuit can be used. But in other applications, that final load may change, or the frequency of operation will change, meaning that a fixed Z-match circuit will not produce the desired results. For these applications, a variable matching network that you can adjust is needed. Better still is a variable and automatic Z-match circuit that adjusts itself to the immediate load or frequency conditions.

Auto Z matching is more common than you think. If you own a recent smartphone, you're probably using an auto Z-match antenna tuner. However, there are other applications. Here's a primer on this topic for your elucidation and cogitation.

Applications are More Common than You Think

The first time I encountered a Z-match problem was when connecting my ham radio gear to an antenna. Most radios—commercial, military, amateur, or whatever—are designed with a 50- Ω output impedance. To get the most power to the antenna, the antenna should have a 50- Ω impedance. In practice, few do. That antenna impedance varies widely with the type of antenna, its installation environment, and the frequency of operation.

The impact of poor impedance matching on a transmitter is a high standing wave ratio (SWR) that will result in lost power (wasted in the transmission line). In fact, the high SWR may actually damage the transmitter output stage. The reciprocal problem exists with a

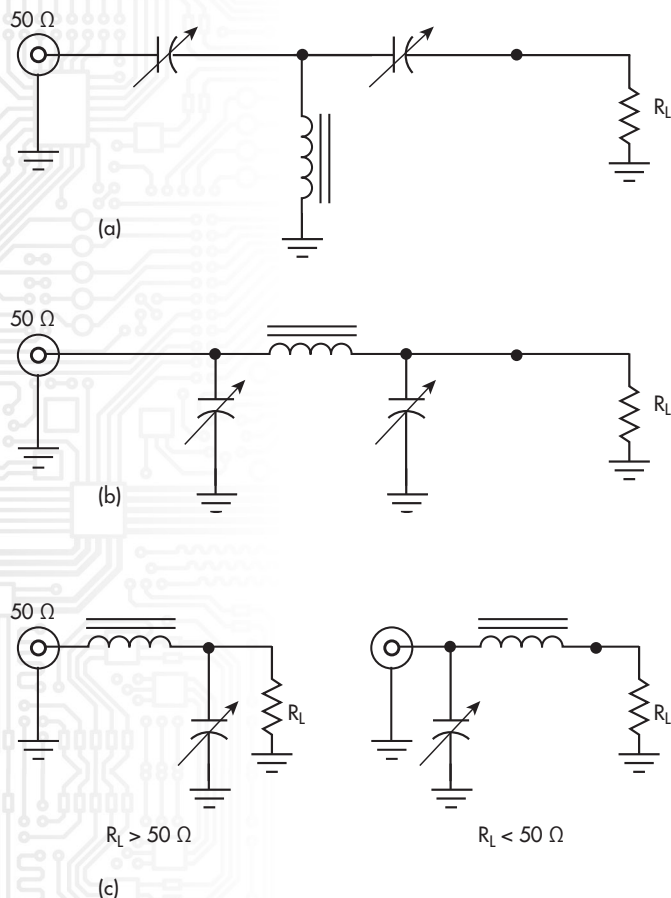

1. The three basic antenna matching circuits: T-network (a), π -network (b), and L-network (c). The L-network is probably the most commonly used.

receiver. Poor Z matching results in weak signal reception.

This problem is easily solved by inserting an antenna tuner between the transmitter and antenna. This is an LC circuit usually consisting of a fixed inductor and one or more variable capacitors. Multiple arrangements are possible. **Figure 1** shows several popular configurations.

The T configuration in **Figure 1a** works well but has a limited range of load (R_L) matching from $50\ \Omega$ to about 5 to $200\ \Omega$. The variable capacitors do the matching. Its range can be expanded somewhat by switching in additional inductors. The circuit also is a high-pass filter. Generally low-pass filter arrangements are preferred, as they take out harmonics and other undesired signals.

The more popular tuner networks are the π and L configurations in **Figures 1b** and **1c**. Both are low-pass filters and will match a wider range of load impedances from a few ohms to over a $1,000\ \Omega$. Multiple variations are possible. Any of these LC circuits can be built to be manually varied so that the antenna impedance looks like $50\ \Omega$ by tuning for the lowest SWR. Note in **Figure 1c** that there are two L-network versions. The choice is made based on the relationship between the input impedance and output load impedance.

Two factors to consider are the insertion loss and power rating of the tuner. Be sure your components can stand up to the transmitter power that could be only a few watts to over a kilowatt and the potential. Second, the tuner will absorb some of that power. A typical insertion loss is in the 0.5- to 1.0-dB range.

A fixed network solution works fine for a given antenna and frequency of operation. If you change the frequency, the antenna impedance will change, creating a mismatch that wastes power. Therefore, you retune again. This is a common problem, as hams like to have a single antenna that can function on multiple frequency bands. A variable tuner enables that one antenna to serve most operating frequencies—it depends on the antenna, though. Readjusting the tuner allows the new conditions to be accommodated and max power is delivered to the antenna.

As it turns out, manually adjusting the tuner is a nuisance, especially if you often change frequencies. Retuning is also necessary if you change antennas. Wouldn't it be nice if that antenna tuner could automatically tune itself to the existing load regardless of frequency? Such a thing actually exists.

An Example Auto Tuner

Paging through a recent *QST* magazine, a ham radio publication of the American Radio Relay League (ARRL), it becomes clear: The greatest number of ads are for antennas and automatic antenna tuners. Who would have thought? Antennas are a major problem for most hams because of the physical installation problems as well as the huge number of choices out there. And matching up the antenna to the transceiver is an ongoing common problem. The automatic tuners fit between the equipment's $50\text{-}\Omega$ input/output impedance

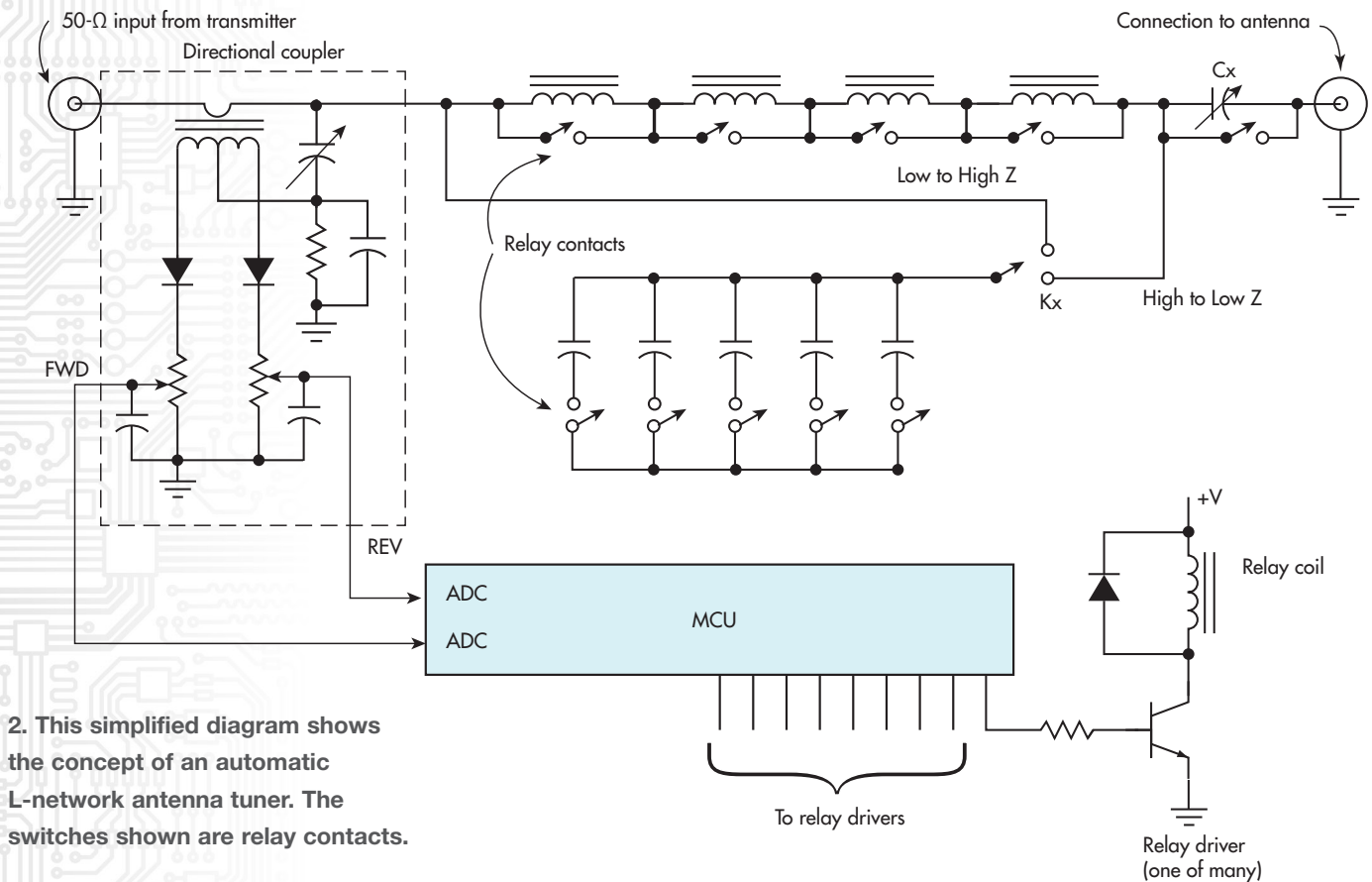

and the transmission line to the antenna.

The auto Z-match unit isn't just a convenience, but a real benefit. It means that you can get by with one antenna on multiple bands. Connecting a mismatched antenna directly to a 100-W transmitter is inviting poor operational results—and possible transmitter damage. An automatic tuner solves the problem.

Connecting the antenna to the tuner and turning on the power causes the tuner to sense any high SWR mismatch and immediately initiate changes in the capacitance and/or inductance values to optimize the Z match. The secret is how to make the L and C values change.

Most auto tuners have fixed inductors and one or more banks of capacitors that are switched by relay. Some units also may have inductors that can be switched in or out. The usual arrangement is to have a microcontroller running an impedance-matching algorithm that adjusts the C and maybe L values until a low SWR, typically <math><1.5</math> to 1 or lower, is achieved. This process usually takes the tuner several seconds or more to run through its routine and find the best match.

Figure 2 shows a simplified circuit of one possible solution. Most designs are some form of low-pass filter that helps minimize harmonics or other spurious emissions. This one implements a basic L network that can be switched from series L in or series L out with relay Kx. A series capacitor Cx is sometimes included to help tune stubborn loads.

The directional coupler in this solution measures the forward (FWD) and reverse (REV) or reflected power levels and produces proportional voltages that are digitized in the MCU

ADCs. The control program sequences through the relay drivers in some pattern to minimize the SWR (lowest REV output). Such a tuner can usually match impedances over a range of about 5 to 1500 Ω .

High-Power Impedance Matching

One of the first automatic Z-match units that I became acquainted with was inside an Applied Materials P5000 RF plasma etcher. These complex machines are used in semiconductor fabs for etching away selected materials from wafers to make ICs. The wafer is placed in a sealed chamber. A pair of electrodes in the chamber, acting like an antenna, receive high RF power. The chamber is pumped full of a gas that will react with the material to be etched away. The RF ionizes the gas, which creates a plasma that reacts with one of the wafer coatings and removes it.

The secret to a consistent even etch is keeping the power to the chamber constant. The problem is that the impedance of the chamber keeps changing as the degree of ionization varies due to the etch process. The solution is an automatic impedance matcher. **Figure 3** shows a hypothetical arrangement.

Power to the chamber can range from a few hundred watts to several kilowatts. The frequency of operation is typically 13.56 MHz, one of the ISM frequencies. Lower frequencies are used as well. An automatic tuner attaches the 50- Ω power amp output to the chamber impedance, which is a complex value usually capacitive, like $20 - j115$.

To handle this power level, large wire inductors and heavy-duty capacitors with wide plate

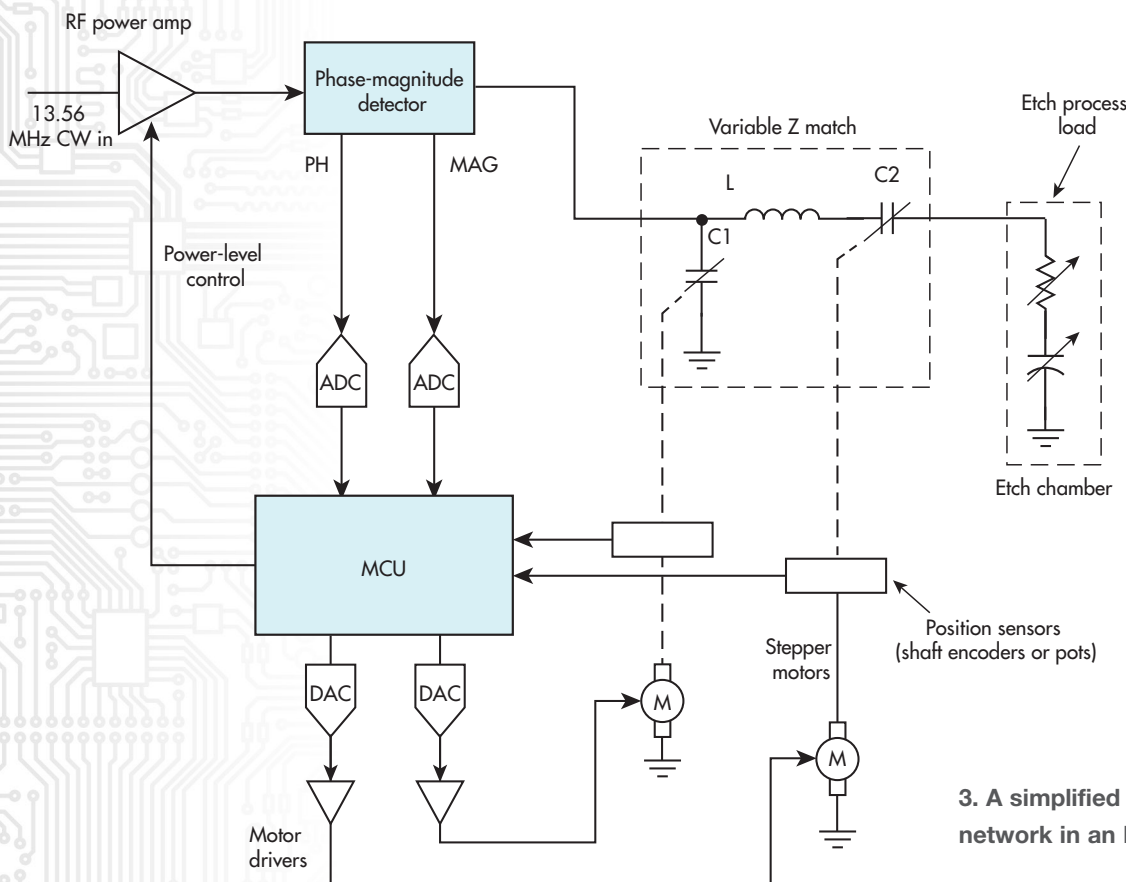

spacing are used in the tuner. The inductor is commonly fixed, though roller contact inductors have been used. Capacitors are usually driven by motors. An SWR-measuring circuit monitors the power amp output and feeds a signal back to a control circuit that continually adjusts the capacitors to maintain a suitable impedance match. Oftentimes, a Smith chart is used to define the load impedance range over which satisfactory etching will occur.

3. A simplified diagram of the Z-matching network in an RF plasma etcher.



The whole thing would not work properly without that automatic Z adjustment. Sometimes, other schemes are employed. For instance, a fixed Z -matching unit may be used while the RF power output can be maintained over a narrow range by varying the RF frequency.

Design Considerations

The main obstacle in designing these circuits is having an appropriate variable capacitor or inductor. Variable inductors are difficult to build. As a result, most auto tuners use variable capacitors. The motor-driven kind are rare, except in the case of high power. Otherwise, the design can usually be implemented with banks of fixed capacitors switched in as needed. Reed relays work fine, but they require a power source. MOSFETs also can be used to perform the capacitor switching. Furthermore, PIN diodes are an option for higher-power discrete component designs.

I have not seen varicaps (varactors or voltage variable capacitors) used, but these may work in low-power applications. Some ICs with switched capacitors also could be applied in low-power situations. In all of these cases, you need a controller to operate the switches. A simple micro will do. The algorithm is the tricky or innovative part of the design.

An important factor is the SWR sensor for feedback. Most of the designs I've seen use a directional coupler like the one in *Figure 2*. This circuit measures forward and reverse power levels and develops proportional dc voltages that go to control the processor. Other techniques include an IQ detector circuit and a phase-magnitude detector.

Some ICs are available to implement the SWR measurement, too. Analog Devices makes the AD8302 gain and phase-detector IC. It needs some directional couplers, but these are usually made with short, coupled lines on a PCB. The AD8361 power-measuring detector could possibly be used. MiniCircuits also makes some circuits that measure phase.

The Smartphone Problem

Automatic Z matching has other applications. Any situation where an antenna can be detuned by nearby objects will benefit from a tuner that automatically retunes to the best conditions. This is a common problem in the modern smartphone, as the main transmit antenna is easily detuned by holding the phone in your hand, putting the phone up to your ear, or laying the phone down near some detuning object.

Detuning is also caused by the close proximity of other antennas in the phone, like those for Wi-Fi, Bluetooth, GPS, and NFC. The problem will worsen when adding multiple MIMO and 5G antennas. And with the millimeter-wave (mmWave) bands, small phased arrays will be incorporated into 5G cell phones.

In addition, detuning occurs when the phone changes frequency as it switches over to another cell site on another band. Most smartphones can cover many different cellular bands, so frequency changes are common. A fixed antenna will almost always be out of tune.

As a result, most smartphones use some form of automatic Z matching to keep the antenna efficiency high and help deliver maximum output power. The antennas in a smartphone are critical. Since they're fixed metal devices, impedance is fixed at their resonant point, but they do have a finite bandwidth. However, their Z changes as the cellular band of operation changes. Smartphone antennas are an inefficient compromise anyway, so

4. Shown is a typical basic smartphone RFFE. (Source: Infineon Technologies, Application Guide for Mobile Communications, 2018/2019, page 24)

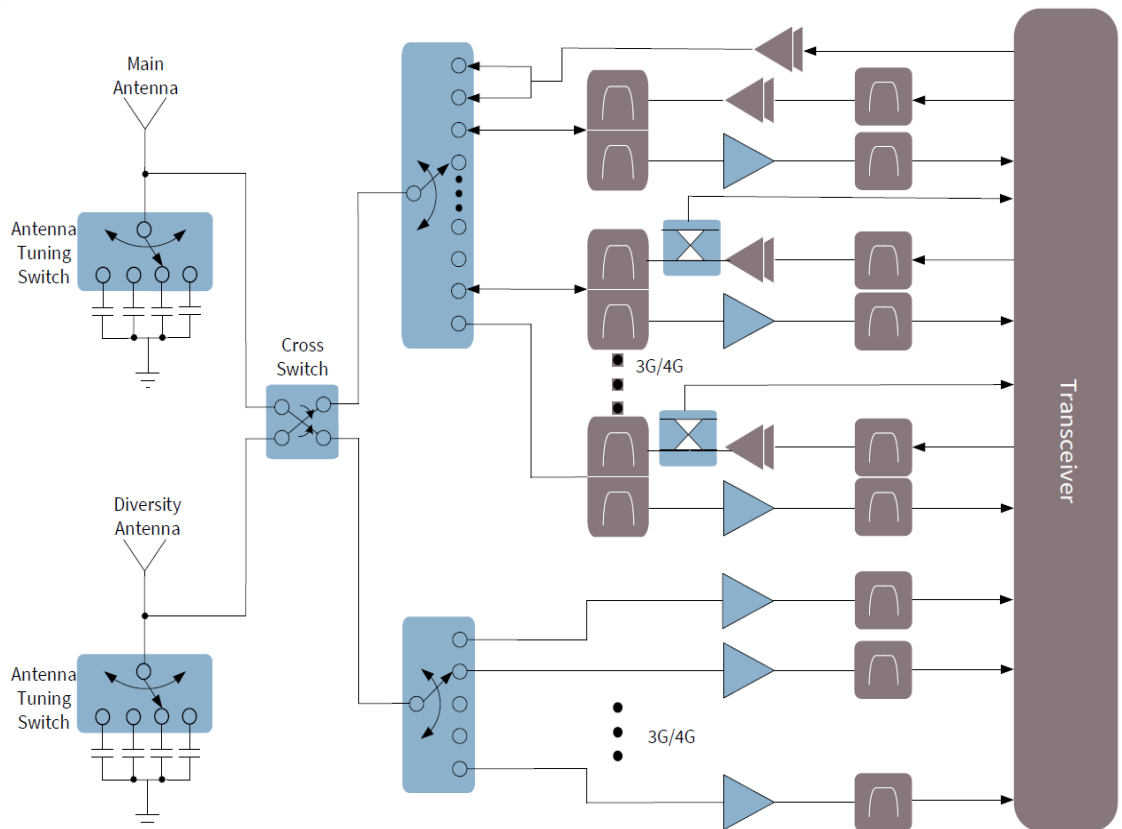

any tuning and matching is essential.

The typical smartphone antenna tuner is a capacitor network switched by MOSFETs. It's a part of the radio-frequency front end (RFFE) that contains the LNAs, SAW/BAR filters, the linear PAs, any antenna tuning circuits, and a sophisticated switching network. **Figures 4 and 5** show a typical RFFE and the block symbols. Several companies make switched-capacitor ICs for this purpose and/or complete RFFEs. The switching is controlled by the smartphone processor. A Mobile Industry Processor Interface (MIPI) is available for this application.

The smartphone keeps getting more complex. Thus, impedance matching circuits must also be used when more MIMO antennas are added to the handsets. The use of carrier aggregation (CA) could really challenge designers. Advanced LTE and 5G can call for up to 4×4 MIMO, meaning four more main antennas. Designers are still learning how to include those antennas so that they won't interfere with one another.

As for CA, the cellular operators are beginning to combine two and sometimes more spaced-out chunks of spectrum to form a single, wide bandwidth channel capable of delivering much higher data rates. How does the RFFE deal with the wide spaced frequencies and maintain some sort of impedance match?

As *Figure 4* shows, the RFFE consists of many band filters and a mix of multi-position electronic switches that can be programmed and connected as needed. All of this is combined with some Z-matching components that are switched in as needed. This RFFE is a simple one for a 3G/4G phone. Advanced 4G LTE and 5G phones will have many more filters, switches, and related components.

In addition to the Z-matching circuits, most smartphone antennas also use what's

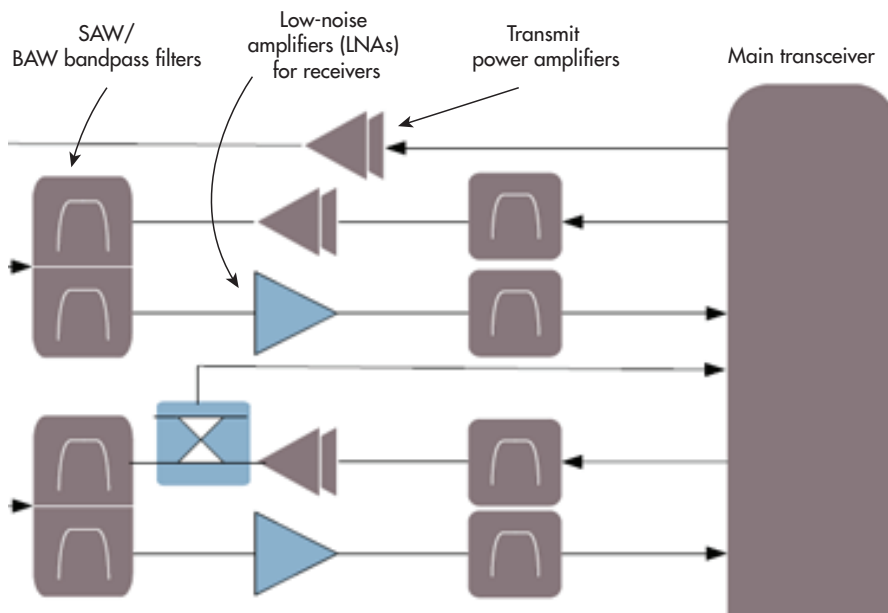

5. This diagram is the legend for Figure 4.

called aperture tuning. Aperture tuning is another method of tuning the antenna to improve its radiation efficiency. As the antennas shrank, with more of them consequently squeezed into the handset, radiation efficiency has declined. Aperture tuning overcomes much of this problem by connecting additional capacitors and/or inductors to the antenna. Like the Z-matching components, the aperture components are switched in with electronic switches.

Figure 6 shows an example with the impedance matching and aperture tuning connections on a planar inverted F antenna (PIFA) used in cell phones. The switches are electronic, and there may be more components and/or more complex networks.

Smartphone antenna matching and aperture tuning are challenging design processes. Such complex design can be acquired rather than designed. Several choices are available—check with vendors like Infineon, Qorvo, Qualcomm, Skyworks, STMicro, and others for suitable RFFE products or reference designs.

to view this article online, [click here](#)

[BACK TO TABLE OF CONTENTS](#)

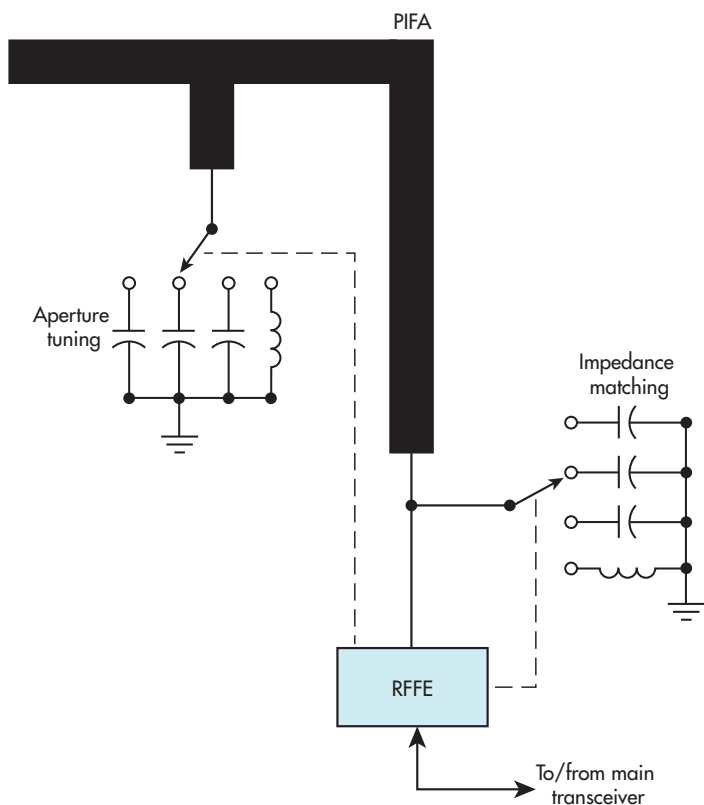

6. Combined impedance matching and aperture tuning of a PIFA.

IMPEDANCE MATCHING: Essential Design Knowledge

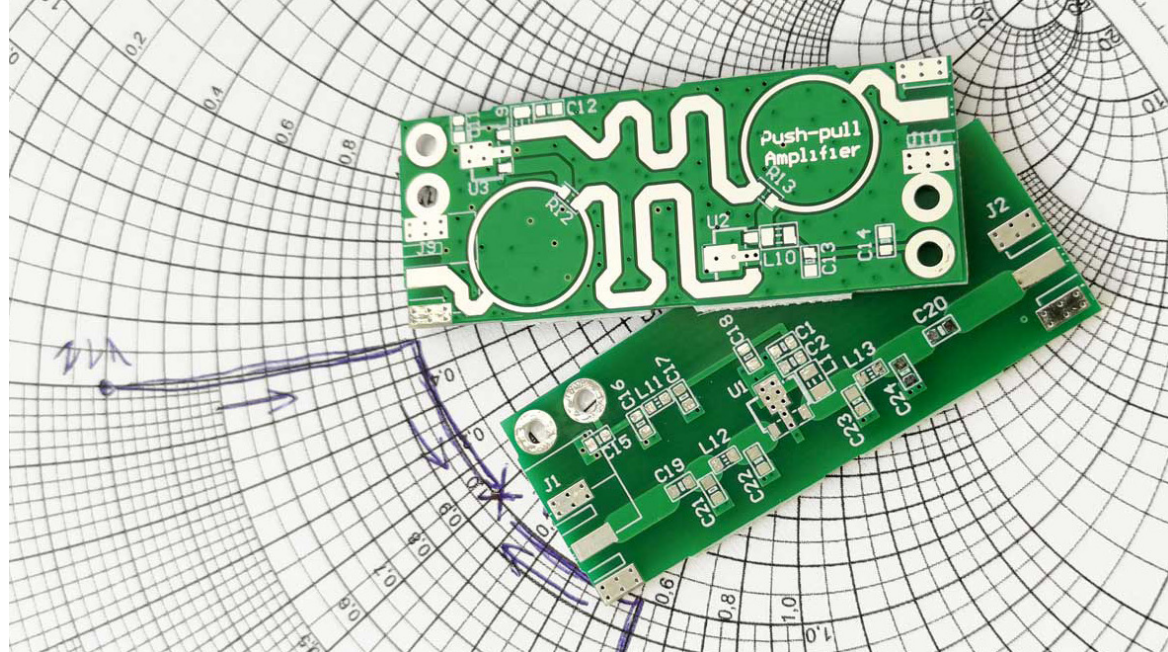

CHAPTER 5:

Impedance Matching Basics: Smith Charts

LOU FRENZEL

This article offers an introduction to the Smith chart and how it's used to make transmission-line calculations and fundamental impedance-matching circuits.

Most of you have probably heard of the Smith chart. The intimidating graph, developed by Philip Smith in 1939, is just about as bad as it looks. How he came up with this is an untold story, but he provided a solution to the complex calculations on transmission lines. And as you will find out, it's useful for working out transmission-line problems and in designing impedance-matching circuits. If you have avoided the Smith chart in the past, here's a primer on how to take advantage of it.

Getting Familiar with the Chart

The Smith chart is made up of multiple circles, and segments of circles arranged in a way to plot impedance values in the form of $R \pm jX$ (Fig. 1). A horizontal line through the center of the main circle represents the resistance with $R = 0$ at the far left of the line and infinite resistance at the far right. Resistance values are plotted on the resistance circles, all of which are tangent to one another at the far right of the resistance line. The $R = 1$ circle passes through the center of the R line.

The remaining curves are parts of circles representing reactance. These curves all come together at the $R = \text{infinity}$ point at the far right. The curves above the horizontal line represent inductive-reactance values and the curves below the line represent capacitive reactance. The Smith chart, as shown, is normalized, thereby permitting you to customize it to your application.

Plotting Values on the Chart

Figure 1 shows four examples of impedance plots:

- $Z_1 = 2 + j0.7$
- $Z_2 = 6 - j2.5$
- $Z_3 = 0.3 + j4$



- $Z_4 = 0.5 - j0.2$

Examine these examples to be sure you understand them.

To use the chart for your own work, you must first set the chart to represent values associated with a specific impedance related to your application. That impedance is usually the characteristic impedance of a transmission line you're using or the input and output impedance of a filter or impedance-matching circuit to be created. Most RF impedances are typically 50 Ω. This value is assigned to the center of the chart where R = 1. The center point then becomes 50 Ω.

To plot a specific impedance, you must adjust it to the main impedance. To do this, you just divide the R and X values by the assigned impedance of 50 Ω, and then plot the normalized value. For example, the value of Z_1 is the normalized value of 100 + j35. And Z_4 is the normalized value of 25 - j10.

Additional Chart Features

Referring again to Figure 1, you will see some scales around the perimeter of the chart. These represent wavelength. The outer scale is a measure of wavelength toward the generator, the next is wavelength toward the load, and the inner scale is the reflection coefficient that's the ratio of the reflected voltage to the incident voltage. At the bottom of the chart are scales for determining the standing wave ratio (SWR), dB loss, and reflection coefficient—all common characteristics of a transmission line.

When working with transmission lines, a main concern is the SWR. If the load is matched to the line and generator impedance, the load will absorb all of the power; there will be no reflections back to the generator. The SWR is determined with the expression:

$$SWR = Z_L/Z_0 \text{ or } Z_0/Z_L$$

Z_L is the load impedance and Z_0 is the characteristic impedance of the transmission line. If $Z_L = Z_0$, then $SWR = 1$. This is the ideal condition so that all of the generator power gets

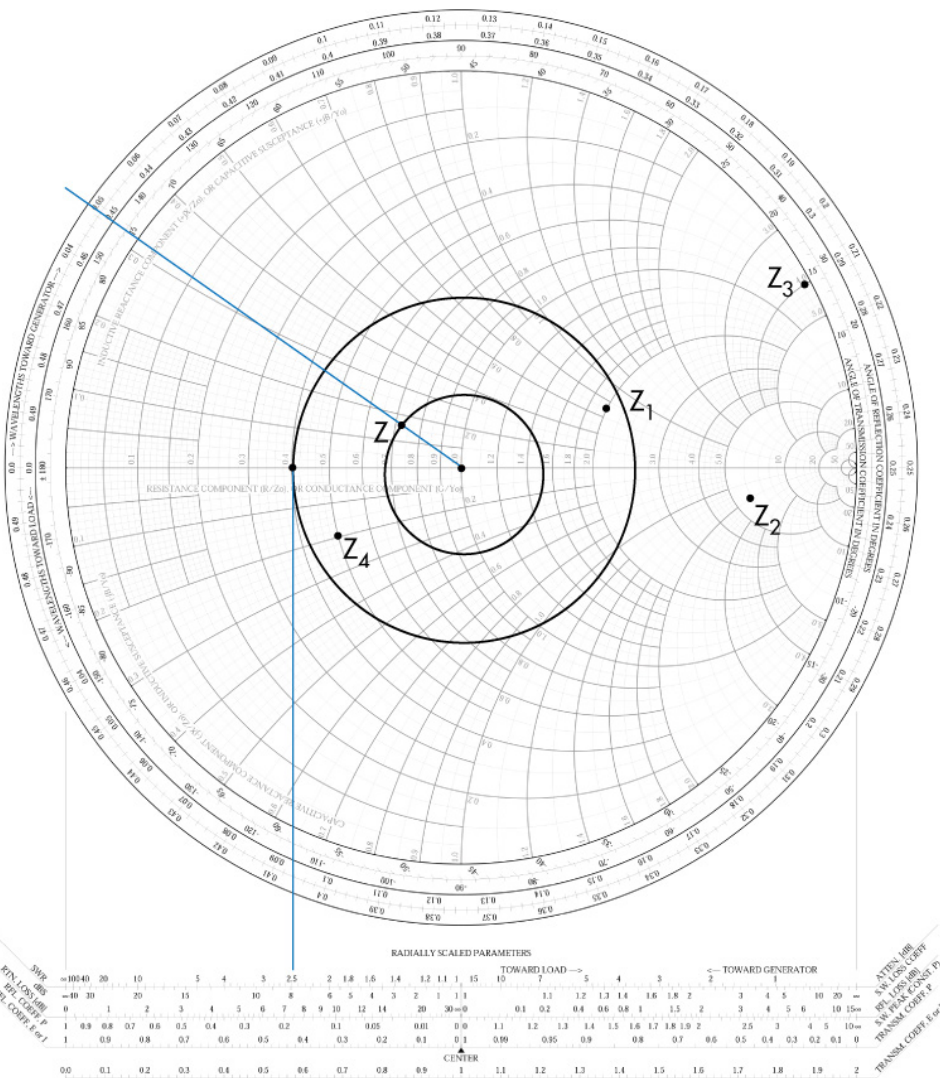

1. Four examples of plotting normalized impedances on a Smith chart.

to the load and any reflections will not interfere with the generator. The center point on the R line represents an SWR of 1. If you trace a line from that center point down so that it intersects with the SWR scale, you see that the value is 1.

If the load doesn't match the line and the driving generator, there will be reflections back along the line. As a result, the load doesn't receive all of the power. The SWR will be greater than 1. Assume an SWR of 2.5 is determined, which is shown as a circle on the chart (*Fig. 1, again*).

Around the perimeter of the chart are additional scales that represent wavelengths. One complete rotation (360 degrees) represents 0.5 wavelength at the operating frequency. One scale is called TOWARD GENERATOR and the other TOWARD LOAD.

At the bottom of the chart, the scales are SWR, reflection coefficient, and return loss.

Another Chart Version

The Smith chart also can be used with admittance (Y), susceptance (B), and conductance (G), with units in siemens (S):

- $G = 1/R$
- $B = 1/X$
- $Y = 1/Z$

Such a chart is a mirror image of the standard chart shown here. For some problems, the admittance version may be easier to use than the standard chart. However, Y values can be read from the standard chart, as you will see later. The best way to learn the Smith chart is to follow some examples.

Example 1

Figure 2 shows a 50- Ω generator connected to a 20-ft. piece of RG-8/U foam coax cable. The characteristic impedance of this cable is 50 Ω and its velocity factor (vf) is 0.80. Remember, the speed of a signal in a cable is slower than it is in free space. The velocity factor indicates this condition as a percentage of the speed in space. That must be considered in determining any impedance-matching solutions.

The line is terminated in a resistive load of 75 Ω . The frequency of operation is 90 MHz. With this combination, what's the impedance that the generator sees at the cable input and what's the SWR?

First calculate the SWR:

$$\text{SWR} = Z_L/Z_0 = 75/50 = 1.5$$

Mark that point on the horizontal resistance line to the right of the center point. Then draw a circle around the center point through the 1.5 mark. This is the SWR circle. You can also draw a vertical line from that point down and it should intersect the SWR scale at the bottom of the chart at the 1.5 mark.

The first step is to calculate the length of the line in wavelengths:

$$\lambda = 984/f$$

where f is in MHz:

$$\lambda = 984/90 = 10.933 \text{ ft.}$$

We can round this to 11.

With a velocity factor of 0.8, the wavelength is:

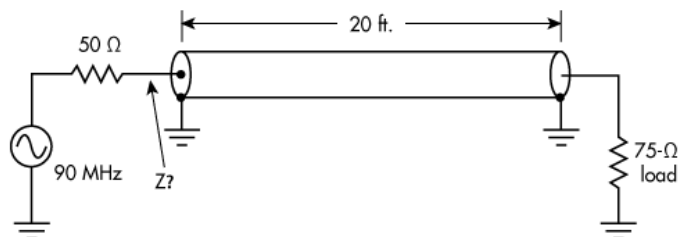

2. The 75- Ω load doesn't match the cable impedance of 50 Ω , which will cause reflections. The SWR is 1.5.



$$\lambda = 11(0.8) = 8.8$$

The 20-ft. line represents:

$$20/8.8 = 2.27 \lambda$$

Round to 2.3 λ . Next, determine the impedance at the generator end of the line.

Starting at the 1.5 mark on the horizontal resistance line, move back toward the generator 2.3 wavelengths. Two wavelengths require four clockwise rotations. Continue to rotate another 0.3 wavelength. That's one more half rotation (one half rotation is 0.25 wavelength) and an additional 0.3 – 0.25 = 0.05 wavelength. After that, draw a line from the 0.5 mark on the outer scale to the chart center. The point on the on the SWR circle where the line crosses is the impedance that the generator sees (*Fig. 1, again*):

$$Z = 0.67 + j0.108$$

Multiplying this normalized value by 50 Ω gives the actual impedance:

$$33.5 - j5.4$$

which is an inductive load.

Example 2

Assume a load impedance of 60 + j40 is connected to the 20-ft. transmission line discussed earlier. What actual impedance will the 50- Ω generator see?

Plot the load impedance on the Smith chart using the normalized value. Then divide the resistance and reactive values by 50 Ω :

$$1.2 + j0.8$$

Once you plot that value, draw the SWR circle through the impedance point. Then extend a line down vertically to the SWR scale at the bottom of the chart. The SWR is about 1.9. Now draw a line through the center point and plotted impedance so that it extends to the TOWARD GENERATOR scale on the outer perimeter.

This line intersects with the scale at 0.17. Since the generator is 2.3 wavelengths away as determined in the earlier example, you move around the circle 2.3 wavelengths. You only need to use the 0.3 value, thus you add it to the 0.17 value to get 0.47. Find that value on the TOWARD GENERATOR scale. Draw a line from the center

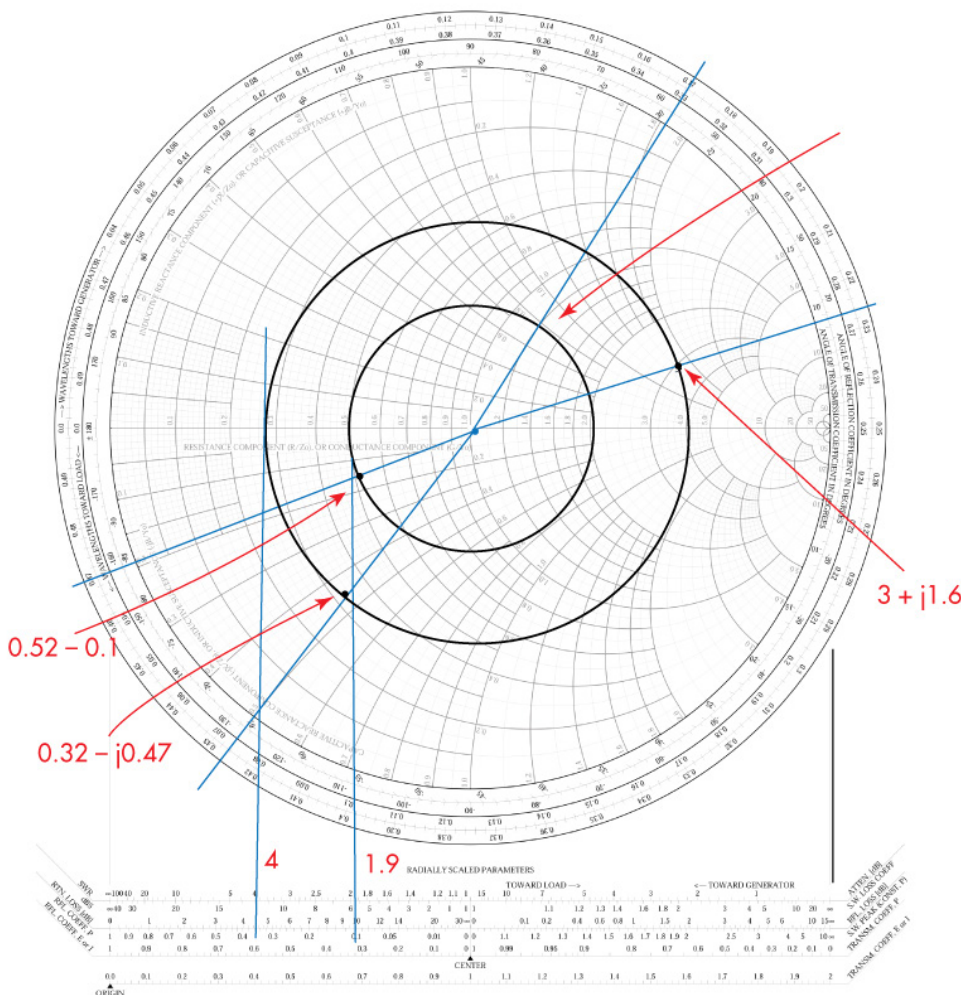

3. This chart depicts solutions to Examples 1 and 2.

point to the 0.47 point. The load that the generator sees is at the intersection of this line and the SWR circle. Reading from the chart you should get:

$$0.52 - j0.1$$

Multiply the normalized value by 50 to get the actual value (**Fig. 3**):

$$Z = 26 - j5$$

Example 3

Suppose that you can measure the overall impedance of the transmission line connected to the antenna. Using an impedance bridge, SWR meter, or similar instrument, you measure a total impedance of the combined transmission line and antenna impedance that would be seen by a generator if connected. Let's say that it is $150 + j80$. We can use the same transmission line and frequency of 50Ω and 90 MHz . The line is 2.3 wavelengths long.

Normalizing the impedance, we get:

$$3 + j1.6$$

Plot the point and draw the SWR circle. Then extend a line down to the SWR scale and read the value of 4 . Next, draw a line from the center point through the plotted normalized value to the TOWARD LOAD scale on the chart perimeter. You should read about 0.273 .

Now rotate in the counterclockwise direction toward the load for 2.3 wavelengths or just 0.3 as before. The intersection will be at the $0.3 + 0.273 = 0.573$ or at the 0.073 mark on the TOWARD GENERATOR scale. Draw a line from the center point to that mark on the outer scale. The antenna impedance will be at the intersection of this line and the SWR circle, which is:

$$0.32 - j0.47$$

The actual value is:

$$Z = 16 - j23.5$$

If you followed this procedure, you noticed that the values are approximate since you must interpolate between the lines. It's like reading from a slide rule, if you're old enough to know what that is.

An Impedance-Matching Example

A well-known and useful impedance-matching technique is to use a quarter-wave matching transformer. This is a one quarter wavelength section of transmission line whose characteristic impedance (Z_0) is determined by the expression:

$$Z_0 = \sqrt{Z_S Z_L}$$

Z_S is the source or generator impedance and Z_L is the load impedance (**Fig. 4**).

To match a $50\text{-}\Omega$ source (Z_S) to a $100\text{-}\Omega$ load (Z_L), a quarter-wave section of transmission line is needed with an impedance of:

$$Z_0 = \sqrt{Z_S Z_L} = \sqrt{(50)(100)} = \sqrt{5000} = 70.7 \Omega$$

This is a workable approach, but it has problems. First, where do you get a $70.7\text{-}\Omega$ line? Second, if the operating frequency is in the low RF range, the line could be many feet

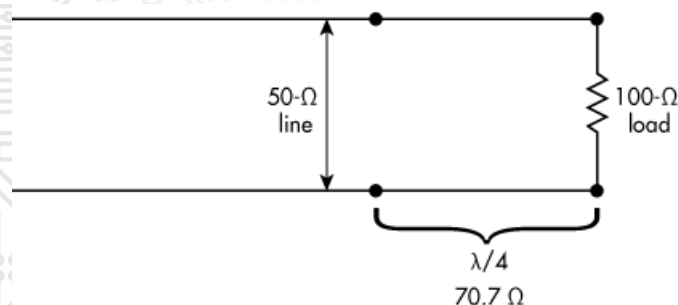

4. A quarter-wave section of transmission line can provide impedance matching. This technique is useful at high frequencies, where stripline can be used.

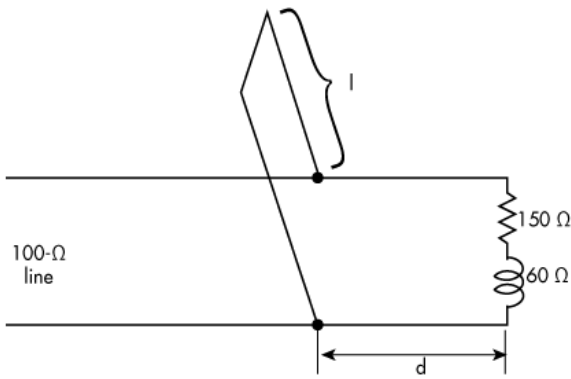

5. A shorted stub is placed at a specific distance from the load and provides impedance matching.

long. Third, the impedances are purely resistive, which isn't always the case in most applications.

However, if you are working at the higher frequencies of hundreds of megahertz or in the gigahertz range, the quarter-wave line will be short. In addition, you can create that line using microstrip or stripline on a PCB with any impedance you want by just adjusting the line widths, line spacing, dielectric material, and other factors involved in designing with microstrip lines. But other factors must be considered, such as when the source and load impedances are complex. This is where the Smith chart can be useful.

One approach to impedance matching is to use shorted transmission-line stubs in parallel with the transmission line. **Figure 5** shows an example. The stub acts as a reactance to cancel out the opposite reactance at a specific point on the line as determined by the load. The objective is to find the length of the stub (l) and the distance from the load (d) where it's to be connected.

Another example will illustrate this scenario. A load impedance of $Z_L = 150 + j60$ must be matched to a 100- Ω transmission line (Fig. 5, again) using these steps:

1. Normalize the load impedance. $150/100 + j60/100 = Z_L = 1.5 + j0.6$. Plot that on the Smith chart at point A (**Fig. 6**).
2. Draw the SWR circle. Then draw a line down from the center of the chart to the SWR scale. It indicates an SWR of 2 to 1.
3. Draw a line from the center point through point A to the perimeter of the chart and read the wavelength on the TOWARD GENERATOR scale. It is 0.052.
4. Convert Z_L to its equivalent admittance. This is done by noting the intersection of the line you just made from Z_L through the center point to the perimeter. The point where the line crosses the SWR circle is Y_L . Its normalized value is $Y_L = 0.53 - j0.23$. Note the change in sign of the susceptance. This is point B in the figure.
5. Move from point B clockwise around the SWR circle until it reaches the $R = 1$ circle on the chart. That is point C in Figure 6. This value is the normalized susceptance. $B = 1 + j0.62$. Draw a line from the center point through C to the perimeter. It should read 0.15 λ .
6. Find the wavelength distance between

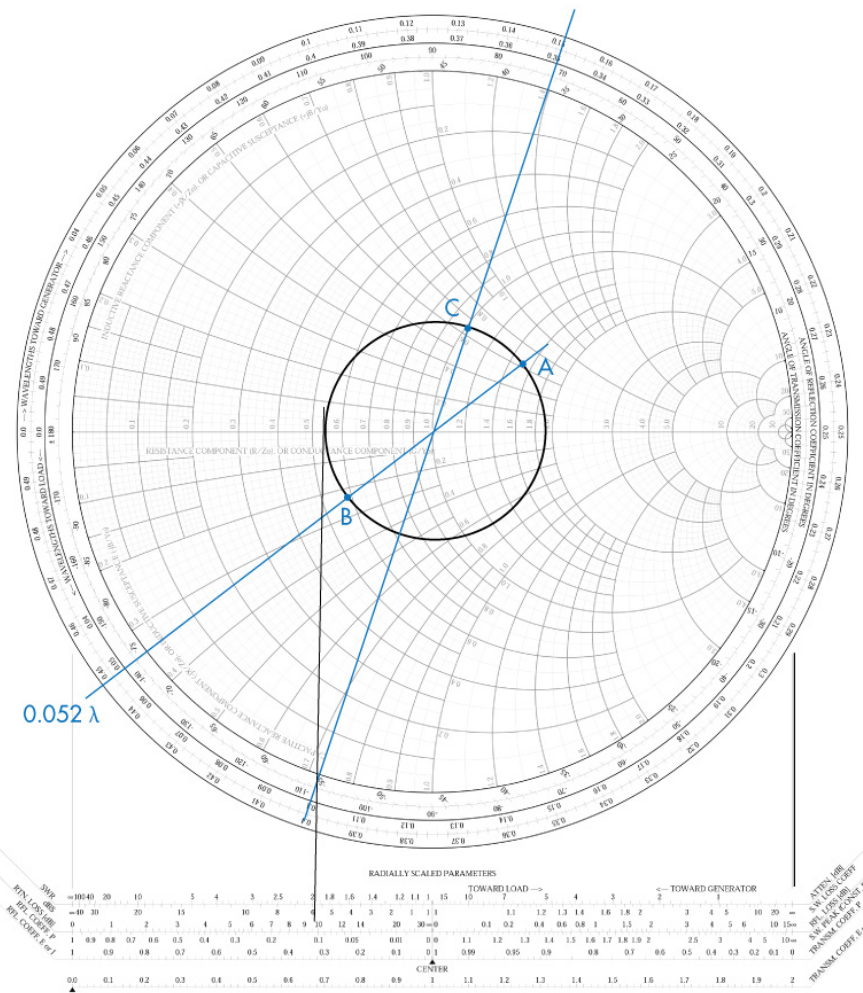

6. The chart illustrates the solution to the shorted-stub matching technique.



the lines intersecting B and C. It is $0.15 + 0.052 = 0.202 \lambda$. This is the distance (d) from the load to the point where the shorted line will be placed.

7. The shorted stub should have the opposite susceptance of the load or $-j0.62$. Connecting susceptances in parallel causes them to add directly and cancel one another.

8. To cancel $1 + j0.62$, we need a stub that will produce $0 - j0.62$. Extend the line from the $1 + j0.62$ point through the center point to the $R = 0$ circle. Read this value on the $R = 0$ circle that's the outer perimeter of the chart. Note the wavelength reading of 0.42λ .

9. Now, move from that value one quarter wavelength (0.25λ). The one quarter wavelength point gives the stub length: $l = 0.42 - 0.25 = 0.17 \lambda$.

10. Now knowing the stub length and distance from the load in wavelengths, you can calculate the actual lengths at the desired operating frequency.

It's important to point out that these values are frequency-dependent. The calculations are for a single frequency. If the line is operated over a wider range of frequencies, there will be some reflections on the line and a higher SWR.

There are other ways to perform impedance matching on a Smith chart. These procedures require the use of the chart's admittance version as well as the standard chart used here.

Conclusion

The Smith chart is a daunting tool. If you followed the examples here, you get the picture. The chart does help to avoid some calculations, but it takes time to master it. If you work enough problems, you will become more adept at using it. Multiple online tutorials and articles can provide additional examples that will show you other ways to use the chart. To find blank Smith charts, search for downloadable charts online; there's a variety of sources.

In addition, you should get yourself a good magnifying glass as the labels and numerical values are tiny and hard to read. A drafting compass also is needed to draw those perfect SWR circles. That will improve the accuracy in reading values from the chart.

Finally, keep in mind that there are multiple sources of Smith chart calculators and software. Most RF CAD software packages include them. Today, though, you may want to just plug in the numbers and let the computer do the work.

"Smith" is a registered trademark of the Analog Instruments Company, P.O. Box 950, New Providence, NJ 07974, 908-464-4214.

References

- Bowick, B., Blyler, J., Ajluni, C., RF Circuit Design, Newnes, 2008.*
- Frenzel, L., Principles of Electronic Communication Systems, McGraw Hill, 2016.*
- Maxim Integrated Products, Application Note 742, "Impedance Matching and the Smith Chart: the Fundamentals," 2001.*

to view this article online,  [click here](#)

 [BACK TO TABLE OF CONTENTS](#)